

MAINE STATE LEGISLATURE

The following document is provided by the
LAW AND LEGISLATIVE DIGITAL LIBRARY
at the Maine State Law and Legislative Reference Library
<http://legislature.maine.gov/lawlib>



Reproduced from electronic originals
(may include minor formatting differences from printed original)

Maine Rabies Management Guidelines

**A compendium of rabies control measures and planning
strategies compiled by the Maine Rabies Workgroup**

3rd Edition, 2012



~This Manual is Available in Alternative Formats~

Foreword

The purpose of this manual and the "Rules Governing Rabies Management" promulgated by the Maine Center for Disease Control and Prevention, the Maine Department of Agriculture-Animal and Plant Health, and the Maine Department of Inland Fisheries & Wildlife is to assist persons charged with the control and prevention of rabies in Maine. Specifically, these guidelines provide:

- A. Information on rabies as a disease
- B. Guidance on the prevention and treatment of rabies exposures in humans
- C. Guidance on the prevention and control of rabies in domesticated animals
- D. Information for municipalities and animal care facilities to inform the development of their own rabies response plans

This revision updates and replaces the previous "Maine Rabies Management Guidelines, 2nd Edition, 2005" and reflects the current status of rabies and antirabies prevention and control measures in Maine. This manual is a compilation of materials based on the Recommendations of the Advisory Committee on Immunization Practices (ACIP) for Human Rabies Prevention, the Compendium of Animal Rabies Control published annually by the National Association of State Public Health Veterinarians, and other peer-reviewed publications. All portions of this manual and other information pertaining to rabies are also available on the Maine CDC website at <http://www.mainepublichealth.gov/rabies>.

In Maine, the primary responsibility for the prevention of rabies lies with the Department of Health and Human Services. However, since rabies generally begins in the wild animal population, moves to the domesticated animal population and then to humans, various state and federal agencies participate in the Maine Rabies Workgroup and assist in the preparation of this manual. These include the Department of Agriculture-Animal and Plant Health, the Department of Inland Fisheries & Wildlife, the United States Department of Agriculture-Animal and Plant Health Inspection Service; private organizations including Maine Veterinary Medical Association, Maine Federation of Humane Societies, Maine Animal Control Officers Association; and the University of Maine Cooperative Extension.

This manual is an ongoing project, and updates will be posted on the Maine CDC website and available for download. When changes and updates are substantial enough, a new edition will be published.

Disease Reporting

Human and animal rabies infections, as well as human rabies post-exposure prophylaxis, are reportable conditions in Maine. Human and animal rabies infections are also nationally notifiable.

Rabies (animal and human)

Healthcare providers are required to report human and animal rabies infections to Maine CDC immediately by telephone on recognition or strong suspicion of disease (22 MRSA §822).

Rabies Post-Exposure Prophylaxis (PEP)

Healthcare providers are required to report rabies PEP to Maine CDC by telephone, fax, or mail within 48 hours of administration (22 MRSA §822). A rabies PEP reporting form (Appendix O) is available on the Maine CDC Disease Reporting website at:

<http://www.maine.gov/dhhs/mecdc/infectious-disease/epi/disease-reporting/index.shtml>. The completed form should be faxed back to Maine CDC. Human rabies PEP has been a reportable condition in Maine since 1996.

Animal bites

While animal bites are not required to be reported to the Maine CDC, any person bitten by an animal suspected of having rabies must immediately notify the municipality in which the bite occurred. The owner, keeper or person having possession and knowledge of any animal exhibiting signs of rabies that has bitten any person or domestic animal must notify the municipality in which the bite occurred (10-144 C.M.R. Ch.251). Municipalities' contact information can be found in the current year's Maine Municipal Directory, a publication of the Maine Municipal Association, or online.

Animal Control Officers or other animal bite responders may use the Maine Animal Bite Report (Appendix E) for documentation. The report should be filed at the Town Office in the municipality in which the bite occurred.

The following is contact information for 24/7 disease reporting and consultation:

Maine Center for Disease Control and Prevention (Maine CDC)

Infectious Disease Epidemiology Program

286 Water Street, 8th Floor, State House Station 11, Augusta, Maine 04333

Telephone (24/7): 1-800-821-5821

TTY: 207-287-8016

Fax: 207-287-6865

Contact List

Maine Center for Disease Control and Prevention (Maine CDC)

24/7 Disease Reporting and Consultation Line 1-800-821-5821

TTY: 207-287-8016

www.mainepublichealth.gov/rabies

Health & Environmental Testing Laboratory (HETL)

207-287-2727

www.mainepublichealth.gov/lab

Maine Department of Inland Fisheries & Wildlife (IF&W)

207-287-5252

TTY: 207-287-4471

<http://www.maine.gov/ifw/>

Weekdays

Game Wardens and Biologists

Ashland 207-435-3231

Bangor 207-941-4440

Gray 207-657-2345

Greenville 207-695-3756

Sidney 207-547-5300

After hours, call local State Police

Augusta 1-800-452-4664

Gray 1-800-482-0730

Houlton 1-800-924-2261

Orono 1-800-432-7381

TTY (Statewide): 1-888-524-7900

Maine Department of Agriculture

State Veterinarian

207-287-7615

Animal Welfare Program

207-287-3846

Pesticide Control Board (bat control questions)

207-287-2731

United States Department of Agriculture, Animal and Plant Health Inspection Service, Wildlife Services (USDA APHIS WS)

207-629-5181

www.aphis.usda.gov/ws/rabies

Animal Control

Call the town office, city hall, or local law enforcement agency

United States Centers for Disease Control and Prevention (CDC)

www.cdc.gov/rabies

Definitions

Animal Control: Control of dogs, cats, and domesticated or undomesticated animals in accordance with 7 MRSA §3948.

Animal Control Officer (ACO): An agent charged with the control of dogs, cats, and domesticated or undomesticated animals or a person acting in that capacity that is appointed periodically by municipal officers pursuant to 7 MRSA §3947.

Animal Damage Control Cooperator (ADC): Also referred to as an ADC agent, a cooperating trapper or hunter certified by the Department of Inland Fisheries & Wildlife and operating as an agent of the Department for purposes of animal damage control.

Confinement and observation: Term used to describe the period of time (10 days) that a domesticated animal, regardless of vaccination status, is to remain separate and apart from other animals and humans and observed after having bitten or otherwise exposed a human or another domesticated animal. Note that the term “10-day quarantine” is commonly used to describe this activity.

Confirmed Rabid Animal: An animal that has been laboratory-confirmed rabid by the Health & Environmental Testing Laboratory using the direct fluorescent antibody test of neural tissue.

Control: To limit by reasonable means exposure of a suspect rabid animal to humans and other animals.

Currently Vaccinated: Domesticated animals are considered currently vaccinated for rabies if at least 28 days has elapsed since the initial vaccination and the duration of vaccination has not exceeded the time period recommended for that species based upon the type of vaccine used. If a previously vaccinated animal is overdue for a booster, it should be revaccinated. Immediately after the booster, the animal is considered currently vaccinated and should be placed on a booster schedule depending on the label duration of the vaccine used. The Maine Certificate of Rabies Vaccination (Appendix J) or a form approved by the Commissioner of the Department of Agriculture, Animal and Plant Health, is proof of immunization.

Decapitate: To remove the head of an animal using methods recommended by the Department of Agriculture, Animal and Plant Health.

Domesticated Animal: Any of various animals that have been tamed and made fit for a human environment, including but not limited to dogs, cats, ferrets, or livestock.

Domesticated Ferret: Refers to *Mustela putorius furo*, a member of the weasel family that was bred by private and commercial breeders and has been domesticated since 600 AD. The domesticated ferret does not include the black-footed ferret.

Exposure: Refers to the threat of rabies transmission when the virus is introduced into bite wounds, open cuts in skin, or onto mucous membranes from saliva or other potentially infectious material such as neural tissue.

Isolation: Term used to describe the period of time (6 months) that an unvaccinated or not up-to-date domesticated animal is to remain separate and apart from other animals and humans if it has itself been exposed to a rabid or suspect rabid animal. Note that the term “6-month quarantine” is commonly used to describe this activity.

Health and Environmental Testing Laboratory (HETL): The state public health laboratory that is part of the Maine Center for Disease Control and Prevention (Maine CDC), Department of Health and Human Services, and that performs rabies testing on animals in Maine that exposed a human or domestic animal.

Incubation period: The time interval between initial contact with an infectious agent (exposure) and the first appearance of signs or symptoms associated with the disease.

Livestock: Horses, cows, sheep, camelids, goats, swine, domesticated deer or any other agricultural mammal.

Mammal: The group of warm-blooded vertebrates (including humans) that nourish their young with milk secreted by mammary glands and have skin covered with hair or fur.

Non-exposure: Indirect contact by itself, such as being in the vicinity of an animal, petting or handling an animal, or coming into contact with the blood, urine, or feces of an animal, does not constitute exposure, and therefore does not require human rabies post-exposure prophylaxis.

Observation: Term used to describe the period of time (45 days) that a currently vaccinated domesticated animal is to be observed for signs of rabies after having been exposed to a suspect rabid animal.

Owned Animal: Domesticated animals, as well as animals in petting zoos and circuses, that have a known owner.

Post-exposure prophylaxis (PEP): Rabies immunization regimen for rabies prevention after exposure.

Pre-exposure prophylaxis: Rabies immunization regimen for rabies prevention before exposure that consists of rabies vaccine only, recommended for individuals that come in frequent contact with animals.

Provoked attack: An attack is considered “provoked” if a domesticated animal is placed in a situation such that an expected reaction would be to bite or attack. This would include, but not be limited to, invasion of an animal’s territory, attempting to pet or handle an unfamiliar animal, startling an animal, running or bicycling past an animal, assisting an injured or sick animal, trying to capture an animal or removing food, water, or other objects in the animal’s possession.

Rabies: Rabies is a viral disease of the central nervous system (brain and spinal cord) caused by the rhabdovirus of the genus *Lyssavirus* which infects mammals.

Rabies Management Guidelines: A manual written by the Maine Rabies Workgroup to provide information on rabies as a disease, to outline prevention and management of rabies exposure in humans, domesticated animals, and wildlife, and to help municipalities and animal care facilities develop rabies response plans.

Stray Animal: Domesticated animals that have no known owner. The term “feral” is sometimes used to describe stray cats and means “a cat without owner identification of any kind that consistently exhibits extreme fear in the presence of people” (7 MRSA §3907).

Susceptibility: The likelihood of contracting a disease after exposure; it varies by species of animal.

Suspect Rabid Animal: Any mammal, domesticated or undomesticated, which is demonstrating signs consistent with rabies or which has potentially exposed either a human or domesticated animal to rabies.

Undomesticated Animal: A mammal considered to be wild by nature by the Department of Inland Fisheries & Wildlife.

Unprovoked attack: An “unprovoked” attack or bite occurs when an animal strikes for no apparent reason. The behavior should be unusual for the particular animal.

Unvaccinated Animal: An animal with no previous rabies vaccination, whose first rabies vaccination was given less than 28 days prior to rabies exposure, who is not up-to-date on its rabies vaccination (the time interval from last vaccination to exposure incident has exceeded the amount of time indicated to be effective by the vaccine manufacturer), an animal for which no record of approved vaccination exists, or an animal for which no approved rabies vaccine exists.

Wild Animal Hybrid: A mammal that is the offspring of a wild animal crossbred to a domesticated animal. This includes a mammal that is represented by its owner to be a wolf hybrid, coyote hybrid, coy dog, or any other kind of wild canid hybrid. Wild animal hybrids are considered wild animals by the National Association of State and Public Health Veterinarians and the Council of State and Territorial Epidemiologists, and should not be kept as pets.

Zoonotic Disease: A disease that is transmitted from an animal to a human.

Table of Contents

Foreword.....	1
Disease Reporting.....	2
Contact List.....	3
Definitions.....	4
Introduction.....	8
Human Rabies Exposure Assessment/Treatment.....	12
Management of Animals that Potentially Expose Humans or Domestic Animals to Rabies	23
Management of Animals Potentially Exposed to Rabies.....	30
Rabies Testing.....	35
Rabies Prevention.....	38
References.....	43
Appendix	
A. Abbreviations.....	48
B. Rabies Submission Form.....	49
C. Rabies Submission Guidelines.....	4:
D. Home Quarantine Notice.....	6;
E. Animal Bite Report.....	52
F. Animal Shelter Adoption Disclaimer.....	54
G. Wildlife Hybrid Notice.....	55
H. Recommended Handling Procedures for Animal Carcasses.....	56
I. Bat Exclusion.....	58
J. NASPHV Form 51, Rabies Vaccination Certificate.....	67
K. Rabies Vaccination Waiver Form.....	68
L. Model Rabies Control Ordinance for Maine Municipalities.....	6:
M. Municipalities' Responsibility to Rabies Control.....	77
N. Formulation of Rabies Prevention Policies in Animal Facilities.....	79
O. Rabies Post-Exposure Prophylaxis Reporting Form.....	82
Figures and Tables	
Figure 1. Map of terrestrial rabies reservoirs in the United States during 2010.....	8
Figure 2. Path of rabies virus in an infected host.....	9
Figure 3. Human Rabies Exposure Assessment Algorithm.....	13
Figure 4. Photo of a Bat Bite.....	27
Table 1. Major Stages of Rabies.....	11
Table 2. Rabies Biologics Available in the U.S.....	12
Table 3. Human Post-Exposure Prophylaxis Schedule.....	21
Table 4. Management of Animals that Potentially Expose Humans or Domestic Animals to Rabies.....	24
Table 5. Management of Dogs, Cats, Ferrets, and Livestock Exposed to Rabies.....	30
Table 6. Human Pre-Exposure Vaccination Guide.....	39
Table 7. Human Pre-Exposure Vaccination Schedule.....	39

Introduction

Rabies is a zoonotic disease caused by RNA viruses in the *Rhabdovirus* family of the genus *Lyssavirus*. This section explains the biology of the rabies virus and the epidemiology of rabies. A thorough knowledge of the epidemiology of rabies, the characteristics of the virus and the manifestation of clinical signs is essential in formulating any rational approach aimed at managing rabies. Animal rabies is endemic in Maine. The last case of human rabies in Maine occurred in 1937. The Mid-Atlantic strain of raccoon rabies did not enter Maine until 1994, but other strains of rabies virus, including fox and bat strains, have been endemic in Maine for much longer. Since then, the majority of animals found to be infected with rabies in Maine have had the raccoon rabies virus strain.

Figure 1 shows the distribution of rabies virus variants in the United States in 2010. The major rabies virus variant seen along the eastern seaboard is the Mid-Atlantic raccoon rabies variant. The variants are determined by laboratory analysis and refer to the species acting as the reservoir. For instance, rabies in a dog as a result of extension from a different reservoir, e.g., skunk, should be referred to as skunk rabies in a dog (1).

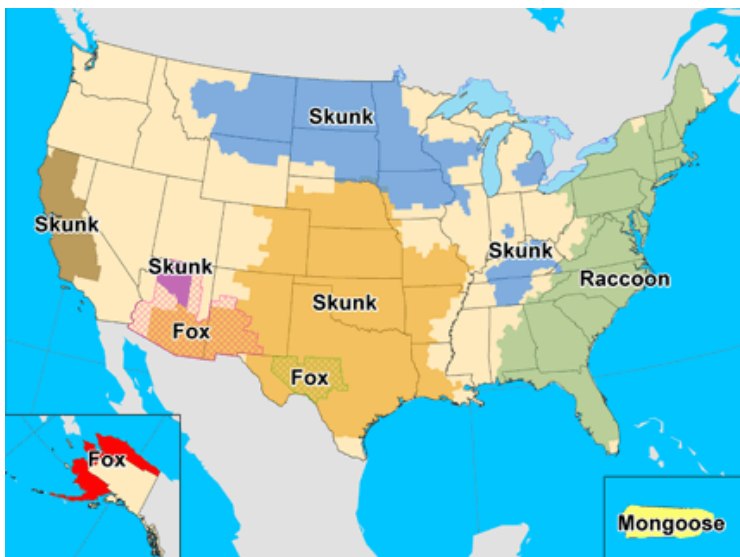

Figure 1. Map of terrestrial rabies reservoirs in the United States during 2010
(CDC. [2011, November 15]. Wild Animals. Retrieved from <http://www.cdc.gov/rabies>)

While the majority of animals testing positive for rabies in Maine are raccoons, rabies has also been found among the following animals: bat, bobcat, fox, skunk, woodchuck, wolf hybrid, cat, and livestock, including cow, horse, and sheep. The latter reinforces the need for animal rabies vaccination of domestic animals and livestock. Maine law requires that cats and dogs be vaccinated for rabies (7 MRSA §3916).

Humans that frequently handle animals may be candidates for rabies pre-exposure prophylaxis. After an exposure, rabies can be prevented in humans with rabies post-exposure prophylaxis. There is no post-exposure prophylaxis available for animals, but there are control measures to protect animals that have may have been exposed to rabies. All of these topics and more are covered in this edition of the Maine Rabies Management Guidelines. Current Maine rabies data are located online at <http://www.mainepublichealth.gov/lab>. National rabies data are available on the U.S. CDC website at www.cdc.gov/rabies.

Rabies Transmission

The most likely mode of rabies transmission is by introduction of saliva containing rabies virus into a bite wound. Rabies transmission can also occur if saliva or central nervous system tissue from a rabid animal contacts a fresh wound or mucous membrane (i.e., lining of the eyes, nose, mouth, genitalia). In the past, aerosol transmission of rabies is thought to have occurred under unusual circumstances in bat caves or laboratories where high concentrations of aerosolized virus were present in a confined area. A small number of human infections have also resulted from corneal and organ transplants, both in the U.S. and worldwide.

Pathogenesis

When rabies virus has been introduced into a wound or onto a mucous membrane, it first multiplies at the site of inoculation. The virus then travels up peripheral nerves to the spinal cord, spreads throughout the spinal cord and brain, and then spreads from the brain to the salivary glands. Clinical signs appear when the rabies virus reaches the brain. This is shown in figure 2 below.

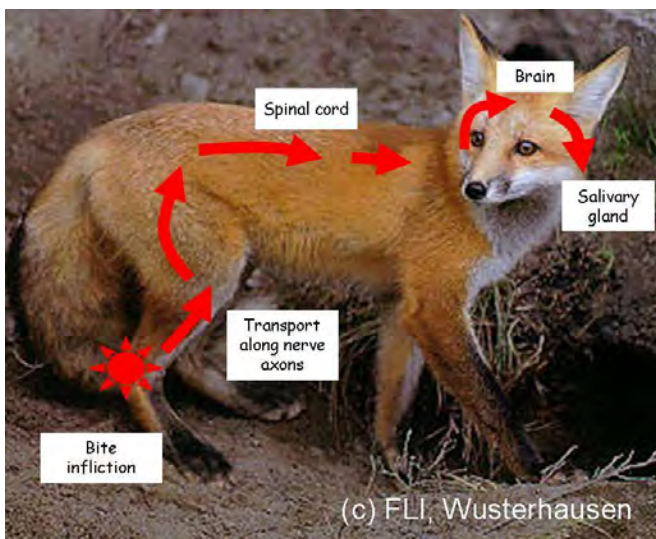

Figure 2. Path of rabies virus in an infected host

(WHO Collaborating Centre for Rabies Research and Surveillance,
http://www.who-rabies-bulletin.org/About_Rabies/Transmission_Pathogenesis.aspx)

Susceptibility

All mammals are susceptible to rabies to varying degrees. For instance, foxes, coyotes, wolves, skunks, bats, cats, and cattle are considered highly susceptible to rabies. However, some animals are very resistant to infection with the virus, including opossums, and are considered at low risk for rabies virus infection (2). The incidence of clinical rabies among rodents (except woodchucks) and rabbits is extremely rare, due to these animals' decreased chance of surviving an attack by a rabid animal, but it has occurred.

Incubation Period

The incubation period is the time interval between exposure to the virus and onset of the first clinical signs/symptoms of disease. The length of the incubation period is determined by several factors including viral strain, dose of virus, site of virus inoculation (bite), age of animal, and many other host factors. The spread of the virus in the central nervous system is relatively rapid.

Average (range) incubation period by species

Cats	3- 8 weeks (2 weeks to 6 months)
Dogs	3- 8 weeks (2 weeks to 6 months)
Ferrets	3-10 weeks
Cattle	2-12 weeks
Horses	3- 8 weeks
Humans	3- 8 weeks (9 days to 7 years)

The incubation period for rabies in wild animals is unknown and extremely variable. Animals can acquire the virus not only through bites from a rabid animal, but also transplacentally (before birth), transmammary (through mother's milk), and/or from eating a dead rabid animal. Once a wild animal gets rabies, it may incubate the disease for a long time without showing signs and may even shed the virus without ever becoming ill. Because of this, wild animals cannot be considered to be free of rabies even if purchased from a pet shop, acquired as a baby, or held for a long period of time.

Rabies Virus in the Environment

The ability of rabies virus to survive depends on the surrounding environment. Normally, rabies virus cannot live long in a warm, putrefied environment, and survives in the body less than 24 hours after death. A few minutes in direct sunlight will inactivate rabies virus. However, under cool conditions (as in refrigeration) it may live for many days, and if the virus is frozen at -70°C , it can live for years. Rabies virus is no longer active in dried saliva and is killed by bleach, ethyl alcohol, soap, detergent, and quaternary ammonium compounds.

Signs/Symptoms of Rabies

In humans, the early signs of rabies are often headache, fever, malaise, and apprehension. Numbness or sensory irritation is often experienced at the site of inoculation. Hydrophobia, aerophobia and excitability are also frequent symptoms. The disease then progresses to paresis or paralysis, delirium, seizures, and coma. Death is generally the result of respiratory paralysis. Once symptoms of rabies appear, there is no effective treatment or cure. Since 2004, three cases of human rabies survived following treatment with the experimental Milwaukee Protocol (3).

Rabies infection in animals has classically been divided into three major stages: prodromal, furious, and paralytic (Table 1). Classical descriptions may be misleading however, as rabies can be quite variable in its presentation. Not all animals pass through all of the clinical stages and the animals may vacillate between stages.

Table 1. Major stages of rabies

Stage	Characteristics
Prodromal	Subtle temperament changes Mild fever Self-mutilation at bite site Slow blink reflexes
Furious	Animal increasingly restless and irritable Visual and auditory stimuli may trigger episodes of aggression and vocalizing May roam long distances May attack inanimate objects and eat odd substances Later loss of muscular coordination, disorientation, generalized (grand mal) seizures Note: Cats especially tend to show furious signs and aggression is common.
Paralytic	Laryngeal/pharyngeal paralysis leads to drooling, changes in vocalization, and difficulty eating, drinking (hydrophobia), and breathing Final stage includes coma and respiratory paralysis leading to death

Infectious Period (Period of Communicability)

The infectious period is the period of time during which a rabid animal is shedding virus in its saliva and is capable of transmitting rabies to another animal or person. Rabies virus must have reached the brain before it can be excreted in the saliva; thus most rabid animals are infectious just a few days before the onset of noticeable symptoms and during the course of the disease. In dogs, cats, and ferrets, communicability is usually 3-7 days before the onset of symptoms (rarely over 4 days) and until the death of the animal.

Diagnosis

Rabies infection is often suspected because of neurological signs that are present in an animal. However, due to the atypical nature of the disease and the unpredictability of clinical signs, rabies should be considered in any animal that suddenly develops profound behavioral changes, or features of limb paralysis, or both. There are several other conditions in the differential diagnoses of rabies.

If a potential rabies exposure occurs, the direct fluorescent antibody (DFA) test is the only acceptable method of determining if the suspect animal has rabies; the 10-day confinement and observation period, which applies only to domestic dogs, cats and ferrets, can only determine if an animal was shedding virus at the time of exposure. The DFA test is a rapid, sensitive, and reproducible laboratory method for detecting rabies antigen in tissue. Fresh brain tissue is preferable and tissue should be stored under refrigeration and should be shipped with ice packs (not wet ice) to the laboratory (see Rabies Testing). All animals excreting virus in their saliva should have virus in the brain detectable by DFA examination, regardless of whether they show neurological signs at the time of examination.

Human Rabies Exposure Assessment/Treatment

Human Rabies Immunizations

Two types of rabies immunizing products are available in the United States for human use. Killed rabies vaccines induce an active immune response that includes the production of neutralizing antibodies in approximately 7-10 days, and usually persists for more than two years. Human rabies immune globulin (HRIG) provides a rapid but short-term passive immunity with an approximate half-life of 21 days.

Table 2. Rabies biologics available in the U.S.

Biologic Type	Product Name	Manufacturer
Human Rabies Vaccine Human Diploid Cell Vaccine (HDCV)	Imovax Rabies	Sanofi Pasteur Phone: (800) 822-2463
	Purified Chick Embryo Cell Vaccine (PCECV)	RabAvert Novartis Vaccines and Diagnostics Phone: (800) 244-7668
Human Rabies Immune Globulin (HRIG)	Imogam Rabies-HT	Sanofi Pasteur Phone: (800) 822-2463
	HyperRab S/D	Talecris Biotherapeutics Bayer Biological Products Pharmaceutical Div. Phone: (800) 243-4153

Rationale for Human Rabies Post-exposure Prophylaxis (PEP)

Prevention of rabies in humans exposed to rabies virus should include prompt and thorough wound cleansing followed by passive vaccination with HRIG and vaccination with cell culture rabies vaccines. Administration of rabies PEP is a medical urgency, not a medical emergency, but decisions must not be delayed. State public health officials should be consulted if questions arise about the need for rabies prophylaxis. Due to periodic nationwide shortages of human rabies immune globulin, the potential for adverse reactions to immunizations, and the costs of treatment, rabies biologics should be used appropriately and judiciously.

The Rabies Exposure Assessment Algorithm (Figure 3) should be used to help determine if rabies PEP is required. The algorithm should be posted or filed in hospital emergency departments for quick reference and guidance. Consultation for assessing the need for rabies post-exposure prophylaxis is available by Maine CDC. After reviewing the circumstances surrounding the bite, the healthcare provider can determine the need for rabies PEP. The correct rabies post-exposure schedule will depend on whether or not the individual has ever received pre-exposure treatment or previous post-exposure prophylaxis; refer to the Human Post-Exposure Prophylaxis Schedule (Table 3). Healthcare providers are required to report rabies PEP to Maine CDC (see Disease Reporting).

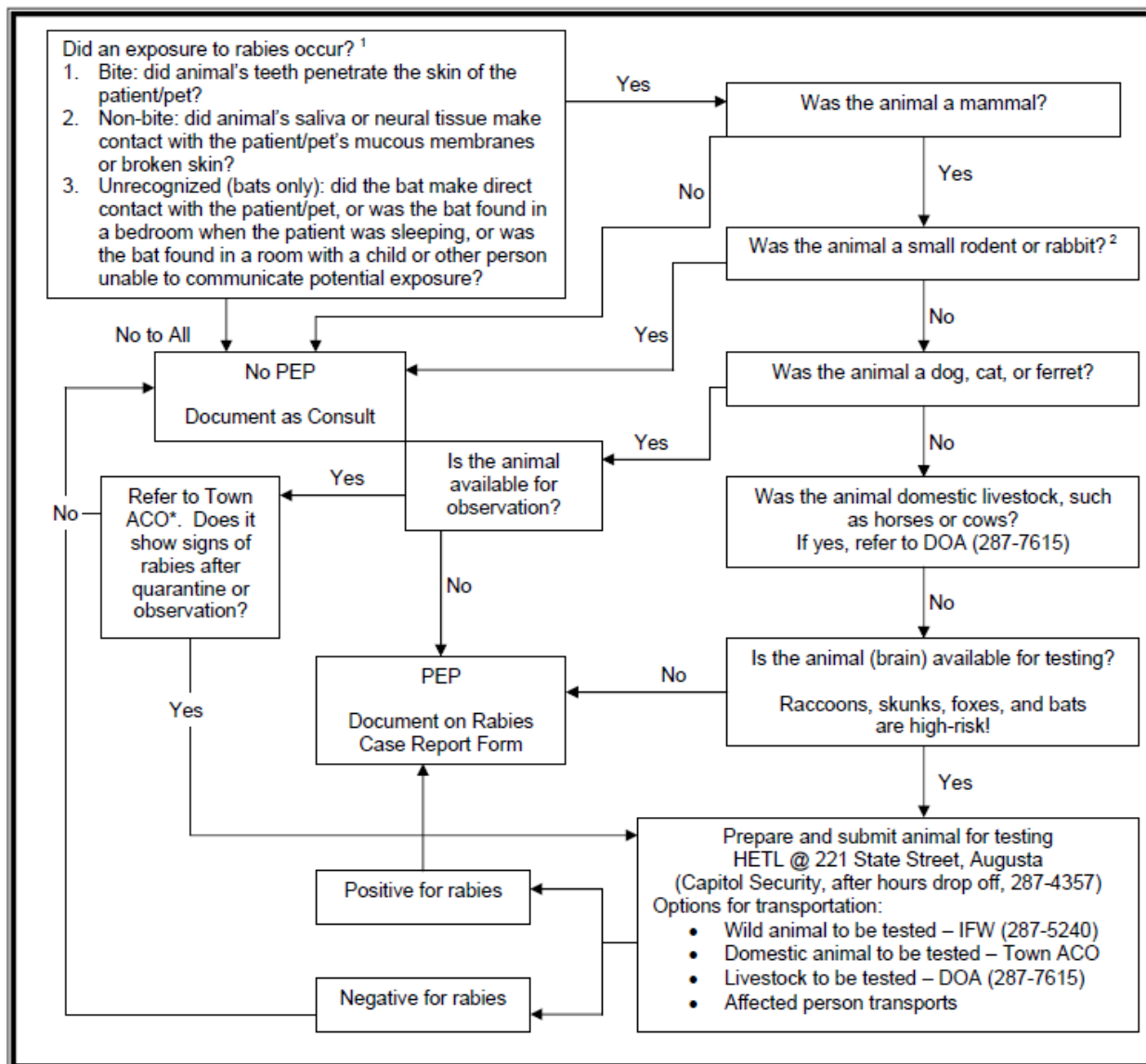

1. Bites from bats and high-risk wild mammals (e.g. raccoons, skunks, and foxes) warrant consideration of immediate post-exposure prophylaxes (PEP). In case of direct contact between human and bat, the possibility of a bite should be considered unless the exposed person can be reasonably certain that a bite did not occur. PEP should be considered for persons who were in the same room as a bat and who might be unaware, or unable to communicate, that a bite had occurred.
2. Rabies has rarely been diagnosed in small mammals such as rabbits and small rodents (e.g., squirrels, chipmunks, rats, hamsters, gerbils, guinea pigs, and mice). Rabbits kept in outdoor hutches may be exposed to rabies; consult Maine CDC (1-800-821-5821) when evaluating potential exposures associated with rabbits in hutches. Rabies has been reported in large rodents (e.g., beavers, woodchucks, etc.) in areas where terrestrial rabies is enzootic.
3. Epidemiologists with questions about rabies exposure assessments may contact Medical Epidemiology, ID Epi Program Manager, or Rabies Surveillance Epidemiologist for assistance.

Figure 3. Algorithm for Rabies Exposure Assessment

(Adapted from CE Rupprecht, RV Gibbons. Prophylaxis against Rabies. NEJM 2004;351:2626-35.)

Health care providers must individually evaluate each human exposure to a potentially rabid animal. These exposures are rarely clear-cut issues, and treatment decisions must take into account a variety of factors. The following factors should always be evaluated and communicated with the patient before specific rabies post-exposure treatment is initiated. These are also described in more depth below.

- Type of exposure
- Extent or severity of the exposure
- Type of animal species involved
- Vaccination status of the animal
- Circumstances (i.e., provoked vs. unprovoked) leading to the bite or other exposure
- Availability of the animal for confinement and observation or testing
- Epidemiology of rabies in the region

1) Type of exposure

Rabies is transmitted to humans only by directly introducing the virus into open cuts or wounds in the skin, or by introducing the virus onto mucous membranes. If no exposure has occurred, post-exposure prophylaxis is not indicated. The likelihood that rabies infection will result from exposure varies with the nature and extent of exposure. Undetected bite exposures to bats are increasingly being linked to human rabies cases in the United States.

Bite exposures

Any penetration of the skin by teeth constitutes a bite exposure. All bites represent a potential risk of rabies transmission. The risk for transmission varies in part with the species of biting animal, the anatomic site of the bite, and the severity of the wound

Non-bite exposures

The contamination of open wounds or abrasions (including scratches) or mucous membranes with saliva or other potentially infectious material (e.g., neural tissue) from a rabid animal is considered a non-bite exposure. Non-bite exposures from terrestrial animals rarely cause rabies. The non-bite exposures of highest risk appear to be among surgical recipients of corneas, solid organs, and vascular tissue transplanted from patients who died of rabies and persons exposed to large amounts of aerosolized rabies virus.

There were two instances of airborne rabies acquired in the laboratory, and two possible airborne rabies cases acquired in a heavily bat-infested cave in Texas. However, alternative infection routes cannot be discounted in these cases. The airborne route of transmission is exceedingly rare and is not expected to occur during typical bat-associated events. Indirect contact and activities (e.g., petting or handling an animal, contact with blood, urine, feces or skunk spray, and contact of saliva with intact skin) do not constitute exposures; therefore, rabies PEP should not be administered in these situations.

Bat Exposures

The most common rabies virus variants responsible for human rabies in the U.S. are bat-related; therefore, any potential exposure to a bat requires a thorough evaluation. If possible, bats involved in potential human exposures should be safely collected and submitted for rabies testing.

The risk for rabies resulting from an encounter with a bat might be difficult to determine because of the limited injury inflicted by a bat bite, an inaccurate recall of a bat encounter that might have occurred several weeks or months earlier, and evidence that some bat-related rabies viruses might be more likely to result in infection after inoculation into superficial epidermal layers (4). For these reasons, any direct contact between a human and a bat should be evaluated for an exposure. If the person can be reasonably certain a bite, scratch, or mucous membrane exposure did not occur, or if the bat is available for testing and is negative for presence of rabies virus, PEP is not necessary. Other situations that might qualify as exposures include finding a bat in the same room as a person who might be unaware that a bite or direct contact had occurred (e.g., a deeply sleeping person awakens to find a bat in the room or an adult witnesses a bat in the room with a previously unattended child, mentally disabled person, or intoxicated person). Other household members who did not have direct contact with the bat or were awake and aware when in the same room as the bat should not be considered as having been exposed to rabies.

Secondary Exposure or “Contact-transfer”

Secondary exposure scenarios (e.g., dog or cat fights with skunk and then transports infectious material from the skunk to human contact) are very unlikely to transmit rabies. These situations are common, but are unlikely to require rabies PEP unless there is clear indication that neural tissue or copious amounts of saliva from a rabid animal were transferred by the pet to eventually contaminate a fresh (less than 24 hours old) skin wound or mucous membrane of the human contact.

Rabies virus is inactivated by desiccation, ultraviolet irradiation, and other factors and does not persist in the environment. In general, if the suspect material is dry, the virus can be considered noninfectious. Rabies PEP is generally not indicated under these secondary exposure incidents. Consult with an epidemiologist at Maine CDC for discussion of specific cases.

Accidental Human Exposure to Animal Vaccine

Accidental inoculation may occur during administration of animal rabies vaccine. Such exposure to inactivated vaccine constitutes no rabies hazard. However, a new category of animal rabies vaccines are vaccinia-vectored. Because vaccinia virus can infect humans and pose a risk for immune compromised individuals, accidental exposures to this type of rabies vaccine should be reported to Maine CDC.

2) Extent or severity of the exposure

In exposures involving multiple severe bites or bites to the face, head or neck, immediate rabies PEP may be considered pending results of 10-day confinement period or rabies testing.

3) Type of animal species involved

Dogs, Cats, and Ferrets

Bites from dogs, cats, and ferrets pose a potential risk of rabies transmission. The driving strategy for managing bite incidents involving these animals is to locate the animal for observation or testing. A healthy domestic dog, cat, or ferret that bites a person may be confined and observed for 10 days under the supervision of the animal control officer in the town where the animal resides. No decision for rabies PEP is necessary while the animal is being confined

and observed. In most cases, the confinement and observation can be managed at the owner's home.

Cats are more commonly involved in exposures than dogs because cats interact more with wildlife, and cat control and rabies immunization regulations are more difficult to enforce. According to the Centers for Disease Control and Prevention, inconsistent use of vaccination in cats over past years has been responsible for an increased incidence of feline rabies in recent years. The frequency of human rabies exposures attributable to cats is increasing at a greater rate than those associated with dogs. Some reports state that rabid cats are more likely than dogs to stalk and attack humans and other animals.

If a biting dog, cat, or ferret is unavailable for testing or observation, the recommendation for rabies PEP is determined on a case-by-case basis. Every effort should be made to locate and apprehend the animal for confinement/observation or testing. If the biting animal is not in custody, but there is a reasonable expectation that the animal can be located and apprehended, consult with Maine CDC at 1-800-821-5821, to determine if PEP may be delayed.

Wild Animals

Some animals are much more likely to be infected with rabies virus than others. For example, carnivorous wild animals (especially skunks, raccoons, foxes, coyotes, bobcats) and bats are the animals most commonly infected with rabies. Weasels, otters, and porcupines may also carry rabies, although it has been shown that wild animals embedded with porcupine quills are more likely to be infected with rabies than the porcupine itself (5). Rabies testing of higher risk wild animals is usually the primary objective. It is preferred that rabies PEP be delayed pending the outcome of rabies test results. Whenever PEP has been initiated and subsequent testing shows that the exposing animal is negative for rabies, PEP can be discontinued. When a wild animal is unavailable for testing, circumstances leading to the bite and the epidemiology of rabies in the animal species of question should be evaluated.

Livestock and Other 'Domesticated' Animals

Livestock, such as horses, cows, pigs, and 'domesticated' wild animals, such as monkeys and llamas, may be infected with rabies, but are considered less likely to be involved in the transmission of rabies. In almost all potential rabies exposure events involving these animals, the animal will be confined and readily available for investigation and a rabies risk assessment.

Small Rodents, Opossums and Lagomorphs

Rodents are not reservoirs of rabies virus. Small rodents (such as squirrels, hamsters, prairie dogs, gerbils, chipmunks, gophers, rats, mice, etc.) and lagomorphs (such as rabbits and hares) are only rarely found to be infected with rabies and have not been known to cause human rabies in the U.S. The reason for this appears to be that these small animals are unlikely to survive an attack from a rabid animal to subsequently develop the disease. Cage-raised animals (hamsters, gerbils, mice, rats, rabbits, etc.) that have been totally confined to an indoor cage are not routinely tested. However, there have been a small number of rabies in rabbits that had been exposed to rabid raccoons while outside. In most cases, bites or other exposures from small rodents and rabbits do not require testing the animal or rabies PEP unless the animal demonstrated unusual aggression or neurologic symptoms or had been housed outdoors.

Opossums have been shown to have a high resistance to infection with the rabies virus and are considered low risk animals for the spread of rabies. Large rodents like woodchucks or

muskrats, however, are more likely to be infected with rabies and exposures involving these animals should be given close evaluation.

Bats

Bats are increasingly implicated as significant wildlife reservoirs for strains of rabies virus transmitted to humans, with the majority of recent human rabies cases being attributed to bat strains of the virus. Recent epidemiological data suggests that transmission of rabies virus may occur from minor or seemingly insignificant physical contact with bats. From 1990 to 2010, there were 60 human rabies cases in the U.S., 47 of which were infected with U.S. indigenous rabies variants (6). Thirty-nine of the 43 indigenous cases (91%) for which a specific rabies virus variant was isolated were infected with bat-associated rabies. Not including the four of these 39 indigenous bat-associated rabies cases that were infected by receiving infected organs or tissues, 27 (77%) of the human cases with bat-associated rabies had a history of bat exposure. Because of this, in all instances of potential human exposures involving bats, the bat in question should be safely collected if possible, and submitted for rabies testing.

Rabies PEP is recommended for all persons with bite, scratch, or mucous membrane exposure to a bat, unless the bat tests negative for rabies. Rabies PEP may be appropriate even in the absence of a demonstrable bite, scratch, or mucous membrane exposure, particularly in situations in which there is reasonable probability that such exposure to a bat may have occurred. Some examples include a sleeping individual waking to find a bat in the room, or an adult witnessing a bat in the room with a previously unattended child, mentally challenged person, or intoxicated individual.

Human-to-Human

Although it can occur, human-to-human rabies transmission is rare. There are documented cases of human rabies in recipients of infected corneal and organ transplants, and two other cases may be attributable to exposure to infectious human saliva. There is one report of transplacental transmission of rabies to a human infant. Persons who are receiving rabies immunizations are NOT capable of transmitting rabies.

4) Vaccination status of the animal

A currently vaccinated dog, cat, ferret, horse, or sheep is unlikely to become infected with rabies. However, healthy domesticated dogs, cats or ferrets that expose humans or other domesticated animals to rabies must be confined and observed for 10 days (if available for confinement) regardless of vaccination status.

5) Circumstances (i.e., provoked vs. unprovoked) leading to the bite or other exposure

An unprovoked attack is more likely than a provoked attack to indicate that the animal is rabid. A provoked incident occurs when a person creates a situation that makes an animal feel threatened and causes them to react by biting or scratching. Provocation is judged from the animal's perspective. An animal will be provoked by infringement on its territory, menacing gestures, handling its young, or fear of injury. Bites inflicted on a person attempting to feed or handle an apparently healthy animal should generally be regarded as provoked.

6) Availability of the animal for confinement and observation or testing

A healthy dog, cat or ferret that bites a human or another domesticated animal should be confined and observed for 10 days (if the animal can be located). Those that remain alive and healthy 10 days after a bite would not have been shedding rabies virus in their saliva at the time of the exposure.

7) Epidemiology of rabies in the region

Incidence of animal rabies varies within the state of Maine. However, only animals that have contact with humans, pets, or livestock are tested, so these data are incomplete, and animal rabies should be considered endemic throughout the state. Refer to the HETL website (see Contact List) for updated animal rabies statistics for Maine.

Treatment of Wounds and Vaccination

Clean the Wound

Bite wounds should be immediately gently irrigated with water or a dilute water povidone-iodine solution. Care should be taken not to damage skin or tissues. In animal studies, thorough wound cleansing alone without other post-exposure prophylaxis has been shown to markedly reduce the likelihood of rabies infection. Thorough wound cleansing will also help prevent other common bite wound infections. Tetanus prophylaxis and measures to control bacterial infection also should be administered as indicated. The decision to suture large wounds should take into account cosmetic factors and the potential for bacterial infections.

Contact Health Care Provider

After cleaning the wound, the person exposed, their parent, or a designated contact should immediately contact a health care provider for treatment of the wound and assessment of the need for rabies post-exposure prophylaxis.

Rabies Post-exposure Prophylaxis (PEP)

There are two regimens for rabies PEP depending upon whether or not the exposed patient has previously completed a pre-exposure series of a cell culture rabies vaccine, has received PEP for a prior rabies exposure event, or has previously been vaccinated with any other type of rabies vaccine and has a documented history of adequate antibody response.

Post-exposure Prophylaxis for Persons NOT Previously Vaccinated for Rabies

If the individual has neither received adequate pre-exposure immunizations nor received a complete rabies post-exposure vaccination regimen, then post-exposure prophylaxis for a rabies exposure consists of:

1. HRIG: 20 IU/kg body weight on day 0. Verify concentration of product. Infiltrate the entire dose into the region of the bite wound; if this is not anatomically feasible, infiltrate as much of this dose as possible into the bite wound, and inject any remaining volume at distant intramuscular site(s).

HRIG is administered only once at the beginning of post-exposure prophylaxis. It is used to provide immediate antibodies until the patient's own immune system responds to immunization. If HRIG was inadvertently not given when rabies vaccination was begun, it can be given up to and including day 7 of the post-exposure series. After the seventh day, HRIG is contraindicated because an active antibody response to the vaccine has presumably occurred. HRIG should not be administered in the same syringe as the vaccine or at the same site as vaccine. As the HRIG may partially suppress active production of antibody, no more than the recommended dose should be given. Prophylactic failure has occurred in other countries when HRIG was not given or was administered incorrectly.

2. HDCV or PCECV: 1.0 ml administered intramuscularly in the deltoid area on days 0, 3, 7, and 14.

Previously, ACIP recommended a 5-dose rabies vaccination regimen with HDCV or PCECV. In 2010, ACIP issued new recommendations that reduce the number of vaccine doses to four. The reduction in doses recommended for post-exposure prophylaxis was based in part on studies indicating that 4 vaccine doses in combination with HRIG elicited adequate immune responses and that a fifth dose of vaccine did not contribute to more favorable outcomes.

For immune competent persons, a regimen of four 1-mL doses of HDCV or PCECV should be administered intramuscularly. The first dose of the four-dose series should be administered as soon as possible after exposure (day 0). Additional doses should be administered on days 3, 7, and 14 after the first vaccination. The number of doses recommended for persons with altered immunocompetence was not changed; for such persons, PEP should continue to comprise a 5-dose vaccination regimen (administered on days 0, 3, 7, 14 and 28) with 1 dose of HRIG (administered on day 0).

Either of the two rabies vaccines currently available in the U.S. can be administered in conjunction with HRIG at the beginning of post-exposure prophylaxis. For adults, the vaccination should always be administered intramuscularly in the deltoid area. For small children, the anterolateral aspect of the thigh is preferred. The gluteal area should never be used for HDCV or PCECV injections because administration in this area results in lower neutralizing antibody titers.

Every attempt should be made to adhere to the recommended vaccination schedules. Once vaccination is initiated, delays of a few days for individual doses are unimportant, but the effect of longer lapses of weeks or more is unknown. Most interruptions in the vaccine schedule do not require reinitiation of the entire series. For most minor deviations from the schedule, vaccination can be resumed as though the patient were on schedule. For example, if a patient misses the dose scheduled for day 7 and presents for vaccination on day 10, the day 7 dose should be administered that day and the schedule resumed, maintaining the same interval between doses. In this scenario, the remaining dose would be administered on day 17. When substantial deviations from the schedule occur, immune status should be assessed by performing serologic testing 7-14 days after administration of the final dose in the series. The two licensed rabies vaccine are considered equally safe and effective. The literature suggests that interchanging vaccines is acceptable, but not ideal (7, 8).

Post-Exposure Prophylaxis for Persons Previously Vaccinated for Rabies

The recommended regimen for an individual who has previously received either the pre-exposure rabies vaccination series OR a complete rabies post-exposure prophylaxis series is:

1. No HRIG
2. HDCV or PCECV: 1.0 ml administered intramuscularly in the deltoid area on days 0 and 3, with the same requirements as noted above.

Table 3. Human post-exposure prophylaxis schedule*

Vaccination Status	Treatment	Regimen
Not Previously Vaccinated	Local Wound Cleansing	All post-exposure prophylaxis should begin with immediate thorough cleansing of all wounds with soap and water
	Human Rabies Immune Globulin (HRIG) [†]	20 IU per kg body weight. As much as possible of the full dose should be infiltrated into and around the wound(s), and the remainder should be administered intramuscularly at an anatomical site distant from vaccine administration. HRIG should not be administered in the same syringe as vaccine. Because HRIG may partially suppress active production of antibody, no more than the recommended dose should be given.
	Vaccine	1.0 ml of human diploid cell vaccine (HDCV) or purified chick embryo cell culture vaccine (PCECV) administered intramuscularly (deltoid area), on days 0, 3, 7, and 14 (day 0 indicates the first day of treatment) [‡]
Previously Vaccinated [§]	Local Wound Cleansing	All post-exposure prophylaxis should begin with immediate thorough cleansing of all wounds with soap and water.
	Vaccine	HRIG should NOT be given. 1.0 ml of HDCV or PCECV administered intramuscularly (deltoid area) on days 0 and 3.

* These regimens are applicable for all age groups, including children.

† If HRIG was inadvertently not given when rabies vaccination was begun, it can be given up to and including day 7 of the post-exposure prophylaxis series.

‡ The deltoid is the only acceptable site of vaccination for adults and older children. For younger children, the outer aspect of the thigh may be used. Vaccine should never be administered in the gluteal area.

§ Any person with a history of pre-exposure vaccination with HDCV or PCECV; previous post-exposure prophylaxis with HDCV or PCECV; or previous vaccination with any other type of rabies vaccine and a documented history of antibody response to the previous vaccination.

Adverse Reactions to Rabies Biologics

Administration of rabies vaccine and rabies immune globulin is not completely risk free. As with any biological product, adverse reactions may occur following the administration of approved human rabies vaccines or HRIG. Although life-threatening reactions are very rare, decisions on the necessity for rabies PEP in non-bite exposures need to include consideration of the risk of the treatment. Health care providers are referred to ‘Human Rabies Prevention – United States, 2008’ (7) and ‘Use of a Reduced (4-Dose) Vaccine Schedule for Post-exposure Prophylaxis to Prevent Human Rabies’ (9) for more details on the types of adverse reactions that can occur, and recommendations for their management.

Once initiated, rabies prophylaxis should not be interrupted or discontinued because of local or mild systemic adverse reactions to rabies vaccine. Usually, such reactions can be successfully managed with anti-inflammatory, antihistaminic, and antipyretic agents. When a person with a history of hypersensitivity to rabies vaccine must be revaccinated, empiric intervention such as pretreatment with antihistamines might be considered. Epinephrine should be readily available to counteract anaphylactic reactions, and the person should be observed carefully immediately after vaccination. Depending on the type of reaction, switching to another manufacturer’s rabies vaccine may reduce the reaction during future immunizations.

Corticosteroids, other immunosuppressive agents, antimalarials, and immunosuppressive illnesses can interfere with the development of active immunity after vaccination (10, 11). For persons with immunosuppression, pre-exposure prophylaxis should be administered with the awareness that the immune response might be inadequate. Immunosuppressive therapy, such as corticosteroids, should never be used to prophylactically treat rabies vaccination reactions, because it may reduce the success of the post-exposure treatment. If corticosteroids are inadvertently used, a serum sample for rabies antibody testing should be collected 14-28 days after the final vaccine dose to verify response to post-exposure treatment.

Pregnancy

Because of the potential consequences of inadequately treated rabies exposure and because there is no indication that fetal abnormalities have been associated with rabies vaccination, pregnancy is not considered a contraindication to post-exposure prophylaxis. If the risk of exposure to rabies is substantial, pre-exposure prophylaxis might also be indicated during pregnancy. Rabies exposure or the diagnosis of rabies in the mother should not be regarded as reasons to terminate the pregnancy.

Patient Assistance Programs

Patient assistance programs that provide medications to uninsured or underinsured patients are available for rabies vaccine and immune globulin. Sanofi Pasteur’s Patient Assistance Program for Imogam® Rabies-HT and Imovax® Rabies as well as other vaccines is administered through the Franklin Group. A healthcare professional or patient can contact the Franklin Group directly at 1-866-801-5655. Novartis’ Patient Assistance Program for RabAvert® is managed through Rx for Hope and can be accessed at 800-244-7668.

Management of Animals that Potentially Expose Humans or Domestic Animals to Rabies

Any animal that potentially exposes a human or domestic animal to rabies should be regarded as a suspect rabid animal until rabies is either ruled out by confinement and observation or testing. Table 4 lists the recommended actions for animals that potentially expose humans or domestic animals to rabies.

Animal bites, particularly dog bites, are a substantial public health problem. There are an estimated 4.7 million dog bites in the United States every year; approximately 16 people die each year in the U.S. from dog attacks. Most bite victims are children under the age of 10 years who potentially suffer disfiguring physical injuries and emotional distress (12). Animals bite to express aggression, fear, territoriality, possession, or a need to escape. Therefore, an animal bite does not necessarily equal a rabies exposure. The spectrum of rabies risk associated with an animal bite ranges from an unvaccinated animal displaying unusual behavior posing the highest risk to a strictly indoor, vaccinated pet at the lowest risk for a rabies exposure.

Any persons bitten by an animal reasonably suspected of having rabies must immediately notify the municipality in which the bite occurred by calling the town office. The owner, keeper or person having possession and knowledge of an animal which has bitten a person or animal or of an animal which exhibits signs of rabies must notify the municipality in which the bite occurred (13). Dog and cat bites occurring outside city jurisdiction and bites from livestock, wildlife, or exotic animals should be reported to IF&W.

Those animals involved in a bite to a human or domestic animal will be managed according to:

- Type of animal inflicting the bite
- Vaccination status of the animal (when applicable)
- Nature and circumstances of the bite
- Relationship of the animal owner to the bite victim

A suspect rabid animal that is captured alive should be managed according to post-exposure procedures as described according to Maine statutes and rule relating to rabies control. If an animal must be euthanized, it should never be shot in the head. The intact brain must be available if rabies testing is warranted. HETL performs rabies testing on wild or domestic animals that exposed humans or domesticated animals. All animals except bats should be decapitated.

Table 4. Management of Animals that Potentially Expose Humans or Domestic Animals to Rabies

Type of Animal	Action Taken
High risk wildlife species (bat, fox, raccoon, skunk, woodchuck, wildlife hybrid, coyote, etc.)	Submit the animal head (exception: can submit entire bat) to HETL for rabies testing.
Other wild mammals (exotics, deer, etc.)	Call Maine CDC at 1-800-821-5821 for guidance.
Owned dogs, cats, and ferrets that appear healthy	Confine and observe the animal for 10 days regardless of vaccination status.
Domestic livestock (horse, goat, sheep, cattle, swine, etc.) that appear healthy	Call Maine CDC at 1-800-821-5821 for guidance.
Domestic animal (dog, cat, ferret, horse, cattle, sheep, goat, swine, etc.) with signs suggestive of rabies	Submit the animal head to HETL for rabies testing.
Stray dogs, cats, and ferrets	Submit the animal head to HETL for rabies testing, or confine and observe for 10 days if town/facility willing
Small rodents (mice, rats, hamsters, gerbils, squirrels, chipmunks, moles, voles, etc.) or rabbits	Neither confinement nor testing of animal is needed unless there are special circumstances. Call Maine CDC at 1-800-821-5821 for guidance.

The following are recommendations for the management of animals that potentially expose humans or domestic animals to rabies.

Dogs, Cats, and Ferrets

Routine Circumstances

Owned dog, cat, or ferret

An owned dog, cat, or ferret that exposes a human or domestic animal should be confined and observed for 10 days regardless of its vaccination status. The confinement may be carried out at the owned animal's residence. The confinement is carried out under the supervision of the local animal control officer in the town where the biting domestic animal resides. Owners of confined animals should be given information about rabies and confinement conditions, which are listed on the Home Quarantine Notice (Appendix D). If the biting dog, cat or ferret is healthy 10 days following the bite, rabies virus was not present in the saliva at the time of the bite.

All dogs, cats, and ferrets showing signs of rabies (i.e. unprovoked aggression, impaired locomotion, paralysis, depression, etc.) at the time of exposure must be examined by a veterinarian to determine if confinement and observation or euthanasia and testing are appropriate, regardless of the animal's vaccination status. If any animal begins to show any illness or unusual behavior during confinement, it must be immediately examined by a veterinarian. If signs are compatible with rabies, the animal must be euthanized, decapitated if necessary by a veterinarian, and the head submitted for testing. Except for shipping and any veterinary fees, there is no cost to the public for rabies testing of the suspect animal. If the signs of illness are determined to be incompatible with

rabies, the animal can be treated appropriately by the veterinarian presiding over the animal's care and remain under observation.

Animals that are not euthanized before the end of the 10-day period shall be visually inspected by the overseeing animal control officer (ACO). Animals were previously required to be examined by a veterinarian at the end of the 10-day confinement period. If the animal appears healthy at the end of the 10-day confinement period, it should be vaccinated or boosted for rabies, if needed, before release from confinement. Dogs, cats, and ferrets should not be vaccinated until the 10-day confinement is completed. If any alteration of normal behavior is observed at the time of ACO inspection, the ACO shall require a veterinary exam for release. If a bite victim requests a veterinary exam following confinement and observation, the exam shall be ordered by the ACO and paid for by the owner or keeper.

Stray or unwanted dog, cat, or ferret

A stray or unwanted dog, cat, or ferret that has bitten a human or domestic animal must be euthanized and tested for rabies. Alternatively, the animal may be confined and observed for 10 days in an animal shelter or facility that is set up to meet the conditions of confinement and that is willing to house the animal during confinement under the supervision of the local ACO. An animal shelter must hold a stray dog for at least eight days before euthanasia unless the dog is severely sick or injured, or if it is extremely vicious (7 MRSA §3913). Stray cats, on the other hand, must be held for 24 hours before euthanasia (7 MRSA §3919). Euthanasia and testing must be coordinated with HETL and the municipality, and any expenses for decapitation, transport and testing are the municipality's responsibility. Upon successful completion of the 10 day confinement, the stray animal may be vaccinated against rabies and placed for adoption at the discretion of the animal control authority.

Special Circumstances

When an animal bite report involves special circumstances, consult Maine CDC for direction on case management. Minor or superficial "nips" or puncture wounds to the face can be managed routinely as described above. Special circumstances include, but are not limited to: bites resulting in broken bones or deep lacerations requiring multiple sutures, a moderate or severe bite to the face or neck, or multiple bite wounds, female dog with a litter of unweaned puppies, biting animal not identifiable in a group or litter, and biting animal transported out-of-state. Additionally, at the discretion of Maine CDC, assistance, therapy, and police dogs may not be required to be placed in confinement during the observation period.

Domesticated Livestock and Owned Exotic Animals

This category includes a broad range of animals from horses, goats, and Vietnamese potbellied pigs to more exotic animals kept as pets or on display to the public, such as lions and monkeys. All bite reports involving this category of animal should be forwarded to Maine CDC as soon as possible. Common livestock are not usually at high risk for transmitting rabies to humans. If livestock bite, scratch, or otherwise expose a human, the risk of a rabies exposure will be determined by the animal's health and behavior, its vaccination status, whether rabies is endemic in the area, the potential for prior exposure of the animal to a rabies vector, and the epidemiology and risk of rabies in the species of animal causing the bite. Prior rabies vaccination may not preclude the necessity for euthanasia and testing. If the biting livestock or exotic animal is determined to pose a significant risk of a rabies exposure, Maine CDC, in consultation with Maine Department of Agriculture, will order the animal to be humanely euthanized and the brain submitted to HETL for

rabies testing.

No scientifically proven period of confinement (like the 10 day period for dogs, cats, and ferrets) exists for livestock. If a livestock species is to be confined and observed, Maine CDC, in consultation with Maine Department of Agriculture, will designate an appropriate duration. The animal should be isolated in a secure stall or separate pen apart from other animals for the designated confinement period. Human contact should be minimal. If the animal escapes and is unable to be observed for the designated confinement period, Maine CDC should be notified immediately. Confinement will be the direct responsibility of the owner; however an ACO will monitor the confinement. A licensed veterinarian must examine the animal at the beginning and at the end of the confinement period. Provided that the confined animal does not exhibit signs of rabies, the following is permitted:

1. Milking of rabies-vaccinated dairy cows
2. Shearing of sheep
3. Slaughter for food use, provided that 21 days have passed since the last rabies vaccination

If confined livestock exhibits abnormal behavior at any time during the designated confinement period, a veterinarian should examine the animal to determine if euthanasia and testing is warranted. If the animal is euthanized or dies before the end of the designated confinement period, it must be decapitated by a veterinarian and the head sent to HETL for rabies testing. Livestock showing signs of abnormal behavior in areas where rabies is known to exist should be suspected of rabies. A veterinarian should examine such animals and determine if euthanasia and testing is warranted. Rendering of animals showing signs of rabies, or confirmed with rabies, is prohibited. In all questionable cases of human exposure to livestock, Maine CDC should be consulted. Maine CDC, in collaboration with Maine Department of Agriculture, will make recommendations to rule out the risk of rabies.

Rodents and Lagomorphs (Rabbits)

Small rodents (such as squirrels, chipmunks, gophers, rats, and mice), opossums, moles, and lagomorphs (such as rabbits and hares), have only rarely been found to be infected with rabies, and have never been implicated as the source of human rabies. Consequently, these types of animals are considered as extremely low rabies transmission risks. Bites from small rodents, squirrels, rabbits, or opossums will almost never warrant rabies PEP. However, if there are unusual circumstances surrounding the bite incident, such as unusual animal behavior, consult Maine CDC for assistance in risk assessment and treatment recommendations.

Healthy caged rodents (such as hamsters, gerbils, rats and mice) and rabbits which have been caged exclusively indoors for the past six months or more and which have not been exposed to any potentially rabid animal pose no risk. Rabies PEP would not be recommended for the exposed human. Rodents and rabbits, which have been caged or kept outdoors, may possibly be exposed to free roaming rabid animals. If a human is exposed to rabies by a rodent or rabbit caged or kept outdoors, submitting the animal for testing must be considered; Maine CDC should be consulted. Domestic rodents and rabbits showing behavioral changes or neurological impairment should be examined by a veterinarian to determine if rabies testing is indicated.

Bats

As bats have been implicated in the transmission of the majority of human rabies in the United States, they merit a separate discussion. First, determine if there is any possibility that human or domestic animal contact with the bat has occurred. Contact would include:

- A bite, scratch, or other direct contact with the bat through a break in the skin or through the mucous membranes of the eyes, nose or mouth
- A bat has been in close proximity to an unattended young child, or a sleeping or impaired person
- A bat is found in a room with an unattended pet
- A pet, usually a cat or dog, is found carrying a live or dead bat in its mouth

If such possibilities cannot be ruled out, the bat should be captured for rabies testing. Only ACOs, game wardens, or pest management personnel should capture live bats.

If a citizen must capture a bat that may need to be tested for rabies, the following technique should be utilized (damaging the bat's head should be avoided as it may prevent rabies testing from being performed):

- Use caution and avoid direct contact with the bat; wear leather gloves if possible
- Wait until it lands, and then cover it with a small box, coffee can, or other container
- Slip a piece of cardboard under the container, thus trapping the bat
- Secure the bat by taping the cardboard tightly to the container
- Wash your hands with soap and water
- Call your local animal control officer, game warden, or pest management personnel to assist in arranging for rabies testing of the bat at HETL.

If it is suspected that a bat had close contact with a human and the bat could not be captured for testing, rabies PEP will likely be recommended in consultation with Maine CDC. Domestic vaccinated animals will be recommended to receive a booster dose of vaccine and observation for signs of rabies for 45 days. Unvaccinated pets will be recommended to be euthanized or isolated for 6 months. If there was no possibility of human or domestic animal contact with the bat, it can be allowed to leave on its own - close the room and closet doors, open windows, turn on a light and observe the bat until it leaves. See Appendix I for a detailed discussion on capturing bats and bat exclusion methods. Remember, if there is possibility of human or pet contact, capture the bat and arrange to have it tested for rabies. Bats have very small and very sharp teeth, and a bat bite may be extremely difficult to detect (Figure 4).

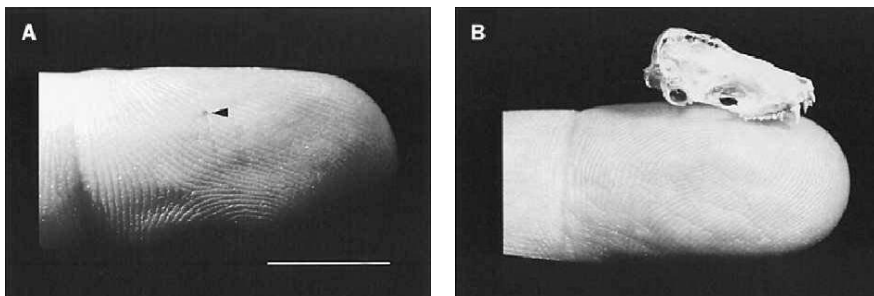

Figure 4. A) Puncture wound on a finger from the bite of a silver-haired bat (a black arrow is pointing at the bite wound). B) Skull of a silver-haired bat on a finger.

(Reprinted with permission from Elsevier (6), courtesy of Alan C. Jackson)

Wildlife Hybrids

As with other wild animals, the length of time required for a wildlife hybrid to start showing signs of rabies after it becomes exposed (incubation period) is unknown. Therefore, in the event of a human or domestic animal exposure, wildlife hybrids, whether vaccinated or not, will be euthanized and tested for rabies. As with other situations involving animals which potentially expose a human to rabies, Maine CDC should be consulted. There is no rabies vaccine licensed for use in wild animals crossbred to domesticated animals, including wolf hybrids. There have been no scientific studies to show that canine rabies vaccine will prevent rabies infection in a wolf hybrid, however Maine State law requires that all wolf hybrids be vaccinated for rabies and that they be permanently identified.

The American Veterinary Medical Association strongly advises that all veterinarians require a client to sign an informed consent release form before vaccinating a wildlife hybrid. Even if a hybrid animal is vaccinated, it will not be considered immunized in the event it is involved in a possible rabies exposure.

Wild Animals

Wild mammals (e.g., skunks, foxes, coyotes, raccoons, bobcats) and bats are considered most likely to be involved in the transmission of rabies, and are considered the cause of most indigenous cases of human rabies in the United States since 1960. A bite from a wild mammal or any type of direct contact with a live bat is considered a serious event. Every attempt should be made to apprehend the animal and submit the brain tissue for rabies testing. If the animal is available for testing, depending on the circumstances, it is generally not necessary to begin rabies PEP unless the laboratory results indicate the animal is rabid. In special circumstances, including severe bites to the face, head or neck, rabies PEP may be recommended before test results are back; consult with Maine CDC. In cases where the animal is under the care of a wildlife rehabilitator, in a zoo, or being kept with a permit, the disposition of the animal should be determined by Maine CDC following a standard bite investigation.

When a wild animal is unavailable for rabies testing, consultation with an epidemiologist regarding recommendations for rabies PEP may be obtained by calling Maine CDC. Common indications of rabies in wildlife include absence of fear, matted fur, discharge from eyes or nose, and lack of coordination. Bats, raccoons, foxes, and skunks are more likely to carry rabies. Young (newborn) of these animals may contain the rabies virus and could transmit the virus to handlers. Feeding, relocating, or other handling of any wildlife without specific permits or licenses is strongly discouraged or prohibited by law. Maine Department of IF&W is responsible for the management and protection of wildlife resources in Maine, including the possession, transportation, rehabilitation or destruction of wild animals. Game wardens have specific responsibilities relating to rabies incidents involving wild animals. Registered animal damage control cooperators are available to assist the Department of IF&W.

Emergencies, including possible or potential rabies exposure to humans or pets should be reported to Wardens or State Police. An official will respond as rapidly as possible and carry out the necessary functions to protect people, capture or destroy a wild animal, and ensure that proper handling and testing is performed. However, if an official response is delayed, or in the absence of a Game Warden, emergency removal of injured or ill wildlife may be carried out by an ACO, wildlife rehabilitator, registered animal damage control cooperator, police officer or other responsible and qualified individual on the scene. The action must be reported to the warden service. Registered animal damage control cooperators and licensed wildlife rehabilitators are not employees of the IF&W, and are under no obligation to respond; they may charge a fee for

services. Fees charged for approved services relating to rabid wildlife may be paid by IF&W. Generally such an agreement must be approved beforehand. For the names and addresses of the registered animal damage control cooperators and licensed wildlife rehabilitators in your area contact your local game warden or see the contact numbers in the beginning of this manual.

Management of Animals Exposed to Rabies

Any animal potentially exposed to rabies virus by a wild, carnivorous mammal or bat that is not available for testing should be regarded as having been exposed to rabies. The following table lists the control measures for domestic dog, cats, ferrets, and livestock that have been exposed to rabies. These control measures differ depending on the vaccination status of the domestic animal at the time of exposure.

Table 5. Management of Dogs, Cats, Ferrets and Livestock Exposed to Rabies

Exposure Category	Vaccinated+	Non-Vaccinated^
Direct contact or visible bite from known rabid animal OR Direct contact with or visible bite or wound from suspect rabid animal (unavailable for testing) OR Wound of unknown origin: suspicious scratch, bite, abscess or wound	1. Booster immediately* 2. Notify ACO 3. Observe for 45 days	1. EUTHANIZE 2. If owner unwilling: a. Notify ACO b. Isolate for 6 months c. Vaccinate on entry or 28 days before release
Exposure by proximity (seen near or in same vicinity of known rabid animal) -no contact or wounds	1. Consider booster* 2. Observe for 45 days	1. Vaccinate at once 2. Observe for 6 months

*If most recent rabies vaccination was given within 28 days, it is not necessary to re-vaccinate.

+Currently vaccinated animals: Animals are considered currently vaccinated for rabies if at least 28 days has elapsed since the initial vaccination, and the duration of vaccination has not exceeded the time period recommended for that species and brand of vaccine.

^Unvaccinated animals: An unvaccinated animal is defined as: an animal with no previous rabies vaccination, one whose first vaccination was given within the last 28 days, one whose last vaccination has expired (per vaccine manufacturer's recommendations), or no approved vaccine exists for the species.

The following are recommendations for the management of animals exposed to rabies by species.

Dogs, Cats, and Ferrets

Currently Vaccinated

When a currently vaccinated dog, cat or ferret is exposed to a rabid or suspect rabid animal, revaccinate as soon as possible after exposure and observe the animal for 45 days. This observation period is necessary because no vaccine is 100% effective and, therefore, it is possible for a vaccinated animal to contract rabies (14). Because rabies is most likely to become apparent within 1-45 days after exposure, this observation period is set at 45 days.

Not Vaccinated or Past-Due on Rabies Vaccination

When a dog, cat or ferret without current rabies immunization is known or suspected to be exposed to a rabid or suspect rabid animal, it should be immediately euthanized. If the owner is unwilling to have the animal euthanized, it should be placed in strict isolation for six months. Isolation in this context refers to confinement in an enclosure that precludes direct contact with people and other animals. Rabies vaccine should be administered upon entry into isolation OR 28 days prior to release; neither is preferred as long as the animal is considered vaccinated by the end of the isolation period. If given at the start of the isolation period, this vaccination does NOT serve as post-exposure prophylaxis for the animal, but may provide protection in the event of another exposure occurring during isolation.

This situation is of the greatest concern to public health officials because of the much greater possibility that a domestic animal will develop rabies if it is unimmunized. Although one would expect onset of illness within 45 days, there have been documented cases where this has occurred in unimmunized pets 5-6 months after exposure. Accordingly, this period of strict isolation is set at six months.

Conditions of Confinement/Isolation

The following is a list of conditions that must be met during both the 10-day confinement and observation period (for a domestic animal that exposes a human or other domestic animal) and the 6-month isolation period (for a domestic animal that is not up-to-date on rabies vaccine and that itself was exposed by a suspect rabid animal).

The dog, cat, or ferret:

1. Must be kept on the owner's premises in an escape-proof building or enclosure (house, garage, etc.) at the responsibility of an adult owner/keeper under the supervision of the local ACO, or in an animal shelter or veterinary clinic (ACO must be notified);
2. May not be allowed to run at large or left outside unsupervised where it may come into contact with other animals, as in a fenced yard or on a chain;
3. Should not be permitted to have contact with other animals or people;
4. If confined and observed at home, cannot be off the owner's property unless being taken to a veterinary hospital for examination or euthanasia under the control of an adult and on a leash or in a carrier.
5. If the animal shows any changes in health or behavior, it must be examined by a veterinarian, who will determine if rabies testing is indicated.
6. If the animal escapes, notify the local ACO immediately.
7. Should not be sold, given away, euthanized or otherwise disposed of during the confinement or isolation period without prior permission from the ACO.
8. Should be visually inspected by the ACO at the end of the 10-day confinement period, or must be examined by a veterinarian at the end of the 6-month isolation period.

The duration and conditions of these periods, as stated on the official notices (Appendix C), start the day of exposure. See the Rules Governing Rabies Management for more information about the conditions of confinement and isolation. Veterinarians or animal owners with questions on how to properly manage pets exposed to a skunk, bat, or a suspiciously acting carnivore that is unavailable for rabies testing should contact Maine CDC.

Livestock

Maine Department of Agriculture manages all cases of livestock exposed to potentially rabid animals. Remember that any animal potentially exposed to rabies virus by a wild, carnivorous mammal or a bat that is not available for testing, should be regarded as having been exposed to rabies. All livestock rabies exposures must be reported to Maine Department of Agriculture and the ACO of that town. The decision on how to handle exposed livestock will be based on the likelihood of rabies in the animal or herd.

All mammalian species of livestock are susceptible to rabies, with cattle and horses among the most frequently infected of all livestock. Horses, cattle or sheep currently vaccinated with a rabies vaccine approved for that species and exposed to a rabid animal should be revaccinated as soon as possible and observed for 45 days. Unvaccinated livestock should be slaughtered immediately. If the owner is unwilling to have this done, the exposed animal can be isolated for six months; any illness in the isolated animal should be reported immediately. Animals maintained in USDA-licensed research facilities or accredited zoological parks should be evaluated on a case-by-case basis. Owned exotic animals/livestock bitten by a rabid animal will likely be subject to euthanasia. Rare or threatened animal species will be evaluated on a case-by-case basis.

The following are recommendations for owners of livestock exposed to rabid animals:

- If the animal is slaughtered within 7 days of being bitten, its tissues may be eaten without risk of infection, provided that liberal portions of the exposed area are discarded. Federal guidelines for meat inspectors require that an animal known to have been exposed to rabies within 8 months be rejected for slaughter.
- As a precaution, neither tissues nor milk from a rabid animal should be used for human or animal consumption. However, pasteurization temperatures will inactivate rabies virus; therefore, if someone drinks pasteurized milk or eats cooked meat, this does not constitute a rabies exposure.
- Having more than one rabid animal in a herd or having herbivore-to-herbivore transmission is uncommon; therefore, restricting the rest of the herd if a single animal has been exposed to or infected by rabies might not be necessary.
- No animal may be slaughtered within 21 days of rabies vaccination.

Signs of Rabies in Livestock

Cattle

The signs of rabies in cattle vary, but some of the following will be found in virtually all animals:

- Straining and repeated efforts to urinate or defecate; the signs may be confused with the typical straining seen at calving.
- Paralysis, often starting in the hindquarters, very often in one leg only, with a typical knuckling of the fetlock joint.
- Loss of appetite and the abrupt cessation of lactation often confused with an intestinal disturbance such as impaction of the rumen or rectum.
- Because of developing paralysis, animals may appear to be “choked,” under no circumstances should anyone put their hands in the oral cavity of these animals in an attempt to examine or medicate.
- Altered facial expression, a very tense alert appearance, and the bells of the ears thrown

forward. The eyes are wide open and follow any moving object with a fixed stare.

- Bellowing is common. The head is extended, the back arched, the flanks tucked in, and a hoarse, sometimes high-pitched bellow is emitted.
- Salivation occurs in less than half the animals affected, and is usually seen as a drooling from the mouth rather than profuse salivation. Rabies in livestock may also produce increased sexual excitement, especially in cattle, with bulls attempting to mount inanimate objects.

Horses

Infected horses exhibit obvious behavioral changes, the majority showing signs of dullness and depression more often than excitement or mania. Frequently, horses become recumbent and wildly scramble and thrash, or appear paralyzed but horses can also exhibit signs of extreme aggression. Death rapidly follows within three to five days of the onset of clinical signs.

Pigs

Pigs may show excitement and a tendency to attack, or dullness and lack of coordination. Affected sows may show twitching of the nose, rapid chewing movements, excessive salivation and convulsions.

Sheep

Rabies may occur in several animals in a sheep flock, since they are more easily bitten by rabid carriers (skunks, foxes and dogs), but may show the onset of symptoms at different times. Sheep have symptoms similar to cattle, and sometimes vigorously pull their wool (15).

Livestock Vaccination

There are licensed vaccines available for horses, sheep and cattle. They can be vaccinated as soon as three months of age, and revaccinated in accordance with vaccine manufacturer's recommendations. According to the Compendium of Animal Rabies Control (16), it is neither economically feasible nor justified from a public health standpoint to vaccinate all livestock against rabies. However, consideration should be given to the vaccination of certain livestock, especially animals which are particularly valuable and/or may have frequent contact with humans, or which are kept in areas where wildlife rabies is known to exist. A licensed veterinarian should be consulted on the advisability of livestock vaccination. Maine Department of Agriculture can also provide information on vaccines for specific species.

The following definitions should aid in assessing the vaccination status of livestock. In all cases, animals are considered vaccinated only if vaccinated by a licensed veterinarian or vaccinated under the direct supervision of a licensed veterinarian. Records must be signed by the licensed veterinarian, and must include the date of vaccination, the type of vaccine used, and the animal identification. Metal ear tags are considered positive identification for livestock. Positive identification for horses might be a drawn picture similar to a Coggins test chart, a photograph, a tattoo or a veterinarian's record. T.B. test chart or similar form may be used for this record keeping. A veterinarian's record may be more practical for individual animals. The State provides an official vaccination certificate on request (Appendix J). There is also an official rabies vaccination waiver form that may be completed by a veterinarian (Appendix K).

Currently vaccinated

Animals are considered currently vaccinated for rabies if at least 28 days have elapsed since the initial vaccination, and the duration of vaccination has not exceeded the time period recommended for that species and brand of vaccine.

Unvaccinated

Animals are considered unvaccinated if no approved vaccine exists for the species (16), if they are vaccinated by someone other than a licensed veterinarian in accordance with the requirement above, or if the vaccination is not within the time frame listed above.

Livestock in isolation

The animal should be isolated in a secure stall or pen apart from other animals for the period of isolation. Maine Department of Agriculture must give permission to move the animal from the farm. Isolation is the responsibility of the owner and the owner assumes all associated risks. The ACO may monitor the isolation. If an animal exhibits abnormal behavior at any time during isolation, a veterinarian should examine the animal. If it is determined to be showing signs of rabies, the veterinarian should decapitate the animal and submit the head for rabies testing. Any animal that dies of unknown causes during the isolation period should also be considered for rabies testing. Milk from the animal should only be used if pasteurized. Raw milk should not be used for the duration of the isolation period.

An animal in isolation should not be sold, given away, euthanized or otherwise disposed of without prior permission from the Maine Department of Agriculture. With permission, it can only be sold (including for slaughter) if not exhibiting signs of rabies, and then the buyer must be made aware that the animal is under rabies observation. The Maine Department of Agriculture must give permission to move these animals from the farm. Any expenses incurred due to rabies exposure of livestock (including decapitation, transportation, and isolation) are the responsibility of the owner.

Rabies Testing

In the State of Maine, the only accepted confirmation of rabies in an animal is the Direct Fluorescent Antibody (DFA) testing of brain tissue. The test is a rapid, sensitive, and reproducible laboratory method for detecting rabies antigen in tissue. Fresh brain tissue is required. Do not fix samples in formalin.

The following guidelines will help in preparing and submitting specimens to the Health and Environmental Testing Laboratory (HETL) in Augusta, Maine, where the testing is done. It should be emphasized that when rabies testing is necessary, timeliness is very important, and a health professional should be consulted early in any potential rabies situation. The decision to submit an animal for rabies testing will ultimately be made by the attending healthcare provider (when a human is exposed) or veterinarian (when a domesticated animal is exposed), and by epidemiologists at Maine CDC.

Testing Criteria

HETL will accept specimens for rabies testing for animals under rabies suspicion which has exposed a human or domesticated animal.

Type of Specimen to Submit

HETL does not accept live animals. Bats are the only exception. Please indicate on the submission form if the bat is still alive. All animals, except bats, should be decapitated by veterinarians or trained personnel before being submitted to HETL. HETL does not have facilities to process carcasses and they will not be accepted or tested. If a bat is submitted for testing, the entire body may be submitted.

Safe Handling of Specimens

Specimens (bodies or heads) should always be handled with waterproof gloves, must be stored and transported in a proper container so that fluid leakage is prevented and that is clearly labeled 'Rabies Suspect.' To clean surfaces and items contaminated by a rabies suspect, use a bleach solution (1/2 cup per gallon of water) as a disinfectant.

If a specimen cannot be sent to HETL immediately, it should be refrigerated. It is important that the brain tissue does not degenerate. A specimen must not be frozen. However, if freezing has occurred, it should be kept frozen and submitted that way to HETL. HETL has a better chance of getting testable tissue if it is thawed at the lab.

Proper Specimen Packaging

Place in a watertight container (well tied, heavy plastic bag or a plastic pail/metal can with tight fitting lid). This container should be placed in a second, larger, waterproof container. If plastic bags are used for both layers, the specimen should then be boxed for more support, easier handling, and labeling. Immediately before transport, the space between the two watertight containers should be packed with ice packs. The ice packs should not be directly in contact with the specimen to avoid freezing it. A Rabies Submission Form should be completely filled out and attached securely to the outside of the packaging. It is suggested that a copy of this form be kept for future reference by those submitting the specimen (Appendix C).

Transport and Delivery of Specimens

- HETL is located at 221 State Street, Augusta, Maine 04333. During regular hours (Monday to Friday, 7:00 a.m. to 5:00 p.m.), call 287-2727. When delivering after hours, use the phone just inside the front door of the building to call security for admittance (287-4154).
- Be prepared- set up your transportation system before it becomes an emergency.
- The responsibility for transporting specimens related to human rabies exposure belongs with the owner of the animal (if known), with the town if the animal is a stray, with the Warden Service if it's wild, or with the family of a bitten person.
- For situations where a domestic animal has been exposed, the animal's owner is responsible for transporting the specimen for testing. Professionals involved in the specific case, whether an animal control officer, animal shelter or veterinarian have a responsibility to help with coordinating transport.
- The Department of Environmental Protection considers the transporting of suspected rabid animals as "Clinical Specimens," not hazardous waste. Below are specimen transportation options; this is not a complete list and some transporting companies listed do not service all areas in Maine.
- Please note: Skunks and other animals which are saturated with skunk spray have been brought to the lab for rabies testing, and the pungent odor has permeated the building when left overnight in the inside refrigerator. To rectify this problem, an enclosed refrigerator has been placed outside the lab entrance door for storing after-hours skunk specimens. HETL requires that all skunks be decapitated and tightly secured in plastic bagging before arriving at the laboratory.

Option 1:

An animal control officer or someone designated by the animal control officer will transport the clinical specimen personally to HETL. Undomesticated animals only: A game warden will arrange transport of the specimen to HETL.

Option 2:

For rural areas: an animal control officer or someone designated by the animal control officer will transport the specimen to an area for pick-up by a delivery service.

Option 3:

Call a delivery service for a guaranteed delivery and for cost information. The State does not pay for transportation of animals to the lab. Transportation fees are the responsibility of the owner of a domestic animal, the town for a stray, or IF&W for wild animals.

- Greyhound: 1-800-231-2222
- FedEx: 1-800-762-3725
- General Courier: 1-800-698-5035, 207-767-6004, S. Portland, Maine
- Bits & Pieces Delivery & Courier Service: 1-800-287-2211, Portland, Maine
- LA Xpress: 207-784-1997, Greene, Maine
- Maine Logistics: 207-942-8752, Bangor, Maine
- Fleet Couriers: 1-800-734-9309

The UPS-United Parcel Service and Express Mail-U.S. Postal Service may not transport clinical specimens, but they are worth a try as some have reportedly been used successfully at times.

Specimen Preparation (decapitation)

When an animal must be tested for rabies, decapitation must be performed by a veterinarian, trained personnel, or trained game warden so that the head alone can be submitted to HETL. All personnel trained to decapitate should receive the pre-exposure rabies vaccine. There has never been a case of human rabies associated with an exposure received during decapitation; however, caution must be taken as the brain, spinal cord, salivary glands and saliva of the animal may contain rabies virus that could possibly cause rabies if splashed onto an open cut or mucous membrane. It is therefore extremely important for the veterinarian as well as any assistants and observers to wear protective gear and exercise caution with the use of sharp objects used during the procedure. If exposure does occur during this process, it must be noted on the laboratory submission form for the animal. If the animal tests positive for rabies, a physician should be consulted as soon as possible concerning the need for rabies PEP for the person involved.

Protective clothing and equipment

- Heavyweight autopsy gloves
- Full face shield
- Protective covering for clothing: surgical gown, plastic apron, coveralls, etc.
- Plastic sheet or body bag to protect surfaces and catch body fluids if procedure cannot be performed in a tub

It is recommended that decapitation be performed in a tub or other easily disinfected area, where body fluids and cleaning solutions can be safely drained away. When farm animals are decapitated, it may be wise to perform the procedure in or very close to the burial hole to minimize surface soil contamination with saliva and CSF fluid. Have a sturdy waterproof container ready to package the head.

Suggested procedure

Place the animal in dorsal recumbency and extend the head by pushing the mandible downward. Make a skin incision immediately caudal to the larynx, then section the trachea and other soft tissues down to the dura. Identify the atlanto-occipital joint by flexing the head, and incise the ligaments to open the joint. Alternatively, forcefully extending the head backwards over a solid object will tear the ligaments, producing an audible and palpable snap. Sever the remaining muscle and skin to completely amputate the head from the body. If cutting through the vertebra is preferred to arthrotomy, shears or a hacksaw can be used to bisect the atlas. DO NOT use an axe, hatchet, or power saw due to the danger created by flying bone and tissue, and the possibility of aerosolizing virus-contaminated fluids. If decapitation of a large animal was performed outdoors, any soil or vegetation contaminated with body fluids should be buried with the animal.

Carcass disposal

Because the rabies virus is primarily concentrated in the brain and salivary glands, only the head submitted for testing is considered medical waste. The remaining carcass can be disposed of in the usual manner, either by incineration (preferred), interment in a pet cemetery, or other burial in accordance with Department of Agriculture Carcass Disposal Rules. See “Recommended Handling Procedures for Animal Carcasses” in Appendix H.

Rabies Prevention

Pre-Exposure Vaccination for Persons at High Risk

Human pre-exposure vaccination against rabies, a series of three injections over a period of 3-4 weeks, is given prior to exposure to the disease. Pre-exposure vaccination is primarily given in order to protect the person against an unknown or unrecognized exposure to the rabies virus, reduce the amount of treatment needed after a known exposure, and protect those whose post-exposure treatment is delayed. Pre-exposure vaccination does not eliminate the need for prompt post-exposure prophylaxis following an exposure; it only eliminates the need for human rabies immune globulin and decreases the number of doses of vaccine required.

Pre-exposure rabies vaccination should be offered to the following persons (Table 6):

- Persons in high-risk groups, such as veterinarians, veterinary technicians, animal control personnel, wildlife rehabilitators, taxidermists, trappers, and rabies testing/research laboratory workers
- Persons whose activities bring them into frequent contact with potentially rabid animals or their CNS tissue.
- International travelers if they are likely to have contact with animals in areas where dog rabies is enzootic, and immediate access to appropriate medical care and biologics might be limited.

Table 6. Human Pre-Exposure Vaccination Guide

Risk Category	Nature of Risk	Typical Population	Pre-Exposure Recommendation
Continuous	Virus present continuously, often in high concentrations. Specific exposures likely to go unrecognized. Aerosol, mucous membrane, bite or non-bite exposure.	Rabies research lab workers*, rabies biologics production workers.	Primary course. Serologic testing every 6 months; booster vaccination when antibody titer falls below acceptable level ⁺
Frequent	Exposure usually episodic, with source recognized. Exposure may also be unrecognized. Aerosol, mucous membrane, bite, or non-bite exposure.	Rabies diagnostic lab workers*, spelunkers, veterinarians and staff, animal control and wildlife workers in rabies enzootic areas.	Primary course. Serologic testing every 2 years; booster vaccination when antibody titer falls below acceptable level ⁺
Infrequent (greater than population at large)	Exposure nearly always episodic with source recognized. Mucous membrane, bite, or non-bite exposure.	Veterinarians, animal control and wildlife workers in areas with low rabies rates. Veterinary students. Travelers visiting foreign areas of enzootic rabies for more than 30 days.	Primary course. No serologic testing or booster vaccination.
Rare (population at large)	Exposures always episodic with source recognized. Mucous membrane, bite, or non-bite exposure.	U.S. population at large, including persons in rabies epizootic areas.	No vaccination necessary.

*Judgment of relative risk and extra monitoring of vaccination status of laboratory workers is the responsibility of the laboratory supervisor.

+ Minimum acceptable antibody level is complete virus neutralization at a 1:5 serum dilution by rapid fluorescent focus inhibition test (RFFIT). Booster dose should be administered if the titer falls below this level. (Adapted from: CDC.MMWR 2008; No RR-57)

Pre-Exposure Vaccination Protocol

Human pre-exposure vaccine is administered intramuscularly (1.0 mL) in the deltoid region with either the HDCV or PCECV vaccines. The initial regimen consists of three doses of vaccine; one each administered on days 0, 7, and 21 or 28 (Table 7). Persons receiving both pre-exposure rabies vaccination and malaria chemoprophylaxis should complete the entire rabies vaccination series prior to beginning malaria chemoprophylaxis. Chloroquine has been shown to interfere with the development of an antibody response to the rabies vaccines, and it should be assumed that mefloquine and other related antimalarials will also interfere with a vaccinee's development of protection against rabies.

Table 7. Human Pre-Exposure Vaccination Schedule

Type of Vaccination	Route	Regimen
Primary	IM	HDCV or PCECV, 1.0 ml (deltoid area), one each on days 0*, 7, & 21 or 28
Booster ⁺	IM	HDCV or PCECV, 1.0 ml (deltoid area), day 0* only

HDCV=human diploid cell vaccine; PCECV=purified chick embryo cell vaccine.

* Day 0 is the day the first dose of vaccine is administered.

+ Administration of routine booster dose of vaccine depends on exposure risk category as noted in Table 6. (Adapted from: CDC.MMWR 2008; No RR-57)

Booster Doses

Rabies antibody titers should be checked regularly according to risk category (Table 6), and a single booster dose of either HDCV or PCECV should be administered only if the titer is less than complete neutralization at a 1:5 serum dilution by the Rapid Fluorescent Focus Inhibition Test (RFFIT). Administering routine rabies boosters without a titer reference is not recommended.

Serologic Testing

An acceptable antibody titer is considered to be complete neutralization at a 1:5 serum dilution or greater by the RFFIT. As stated above, when a titer is measured at less than a 1:5 serum dilution, a booster dose of rabies vaccine is recommended. Two types of test options are generally offered. In a screen test, the serum is tested at two dilutions only and simply tells the patient if a booster dose of rabies vaccine is indicated. An end-point titer test is used to measure the exact titer level by testing the serum at serial dilutions until an end-point is reached. All labs require 2 mL of refrigerated serum. Contact the laboratory by phone or through a website address to receive the proper forms and shipping instructions. Routine serologic testing following the primary pre-exposure series is not necessary due to the excellent antibody response following the recommended vaccination protocol. Persons in the Continuous or Frequent risk categories should receive regular serologic evaluation of their rabies antibody titer per Table 6.

The exception to this is those patients suspected of being immunosuppressed while undergoing the primary pre-exposure vaccination series. Patients who are immunosuppressed by disease or medications should consider avoiding activities for which rabies pre-exposure prophylaxis is indicated so that they may postpone pre-exposure vaccinations. If that is not possible, immunosuppressed persons who are at risk for rabies exposure should be vaccinated and their antibody titers checked to confirm seroconversion after the vaccination series is completed. Failures to seroconvert after the third dose should be managed in consultation with Maine CDC. While the currently available cell-culture rabies vaccines are extremely effective, easier to administer and less painful than in the past, they are also very expensive. It is estimated that about 40,000 people receive rabies PEP in the U.S. every year. The estimated cost per person for rabies post-exposure treatment is \$2,000 to \$3,000. The cost of rabies pre-exposure prophylaxis is a fraction of that cost. See Table 2 for information on the currently available rabies biologic products and how to contact the manufacturers.

Education

Education for the general public can reduce or prevent human exposures to potentially rabid animals. Local town officials, including animal control officers and health officers, should make available to residents in their towns any information on rabies produced by Maine CDC, Maine Department of Agriculture, Maine Department of Inland Fisheries & Wildlife, Maine Veterinary Medical Association, Maine Federation of Humane Societies, and Maine Animal Control Officers Association, as well as what is included in this manual.

Education for the general public should emphasize the following steps to decrease human exposure to rabies:

- Avoid sick or strange acting animals and report them to the local ACO.
- Vaccinate all cats and dogs against rabies, and vaccinate livestock when recommended by a veterinarian.
- Do not pick up, touch or feed wild animals or unfamiliar animals. Do not leave pet food outside for any reason. Feeding wildlife not only increases the risk of rabies exposure but also is not healthy for the animals themselves. It permits animal populations to increase beyond normal limits and can lead to obesity, dental disease and unnatural social behavior.
- Do not ‘rescue’ seemingly abandoned baby wild animals. In most cases when a baby animal is found, the parent is nearby waiting for humans to leave. Attempting to raise young wild animals is very rarely successful and even if it is, the result is a wild animal which does not know how to live in the wild.
- Do not keep wild or exotic animals as pets. Maine State law requires a permit for wildlife rehabilitators and others having wild animals in their possession.
- Use only animal proof trash cans. Garbage attracts wildlife.
- Cap chimneys and seal openings and cut tree branches that provide access to houses, garages, etc., to prevent raccoons and bats from entering. Raccoons especially have adapted very well to living closely with humans. Although not normally seen due to their nocturnal habits, their numbers are often higher in suburban and urban areas than in more rural locations due to the presence of food and nesting sites.
- If bitten or scratched by any animal, one should immediately gently irrigate the wound with water or a dilute water povidone-iodine solution and contact a health care provider to assess potential rabies exposures.
- If a pet is bitten or scratched by another animal, gloves should be worn when handling or cleaning the wound. Afterwards, wash hands thoroughly. Contact a veterinarian to determine if the pet requires treatment, including a rabies booster.
- Teach children to keep a safe distance from wildlife and strays.

Pet Vaccination

A reduction in rabies in both humans and pets was not possible until widespread rabies vaccinations of dogs became available in the 1950s. Vaccination of dogs and cats provides an effective buffer zone between rabid wild animals and humans, and has been instrumental in reducing the impact of rabies in the United States. Maine law requires that all dogs, cats and ferrets be vaccinated against rabies (7 MRSA §3916 and §3922). Animal rabies vaccinations must be administered only by, or under the direct supervision of, a licensed veterinarian. This is the only way to ensure that rabies vaccines have been properly administered. Rabies vaccinations given by the owner/keeper of an animal are not acceptable and the animal will not be considered vaccinated in the event of a rabies exposure.

A dog or cat is considered currently vaccinated if at least 28 days have elapsed since the animal's initial vaccination, and the duration of vaccination has not exceeded the time period recommended for that species and brand of vaccine. All dogs and cats should be vaccinated against rabies for the first time according to the recommendations of the vaccine manufacturer. The animal's first booster (regardless of the age at initial vaccination) should be given one year later. The animal should then receive booster immunizations according to the recommendations of the vaccine manufacturer. The Maine Certificate of Rabies Vaccination (Appendix J) or a form approved by the Commissioner of the Department of Agriculture, Division of Animal and Plant Health is proof of immunization. The Maine Animal Rabies Vaccination Waiver Form (Appendix K) may be completed by a veterinarian when indicated.

A municipal clerk may not issue a license for a dog until the applicant has filed with the clerk proof that the dog has been immunized against rabies in accordance with rules adopted by the Commissioner of Health and Human Services, except that the requirement of immunization may be waived by the clerk under conditions set forth by the Commissioner of Health and Human Services (7 MRSA §3922). No tags or licensure are required for cats at this time.

Local Animal Control

Management of stray and unwanted dogs and cats is also essential to a successful rabies control program. Please refer to Maine statutes and rule related to rabies control. Every municipality is required by state law to have or work with a state licensed animal shelter (7 MRSA §3949). It is unlawful for any dog, licensed or unlicensed, to run at large (7 MRSA §3911).

Wildlife Control and Management

Inland Fisheries and Wildlife has jurisdiction over the management and control of all wildlife in Maine. Wildlife rehabilitators (who must be licensed) should use extreme caution when handling wildlife. If high-risk species are released, following care and rehabilitation, the release should be in the vicinity from where the animal was taken. This is a rabies control measure and also prevents the animal from being placed in another animal's territory. The reduction of wildlife populations is not considered a viable approach to rabies management. Removal of specific animals from areas where there is an increased risk to human safety may be considered by the Department of Inland Fisheries and Wildlife.

References

1. Aiello SE, ed. Rabies. Merck Veterinary Manual. 8th ed. Philadelphia: Merck & Co., Inc., 1998:966-970.
2. Jackson AC and Wunner WH, eds. Rabies, Second Edition: Scientific Basis of the Disease and Its Management. 2nd ed. Amsterdam: Elsevier, Inc. 2007.
3. Blanton JD, Palmer D, Dyer J, Rupprecht CE. Rabies surveillance in the United States during 2010. *J Am Vet Med Assoc* 2011;239:773-783.
4. Feder HM Jr, Nelson R, Reiher HW. Bat bite? *Lancet* 1997;350:1300.
5. Rosatte R, Wandeler A, Muldoon F, Campbell D. Porcupine quills in raccoons as an indicator of rabies, distemper, or both diseases: Disease management implications. *Can Vet J* 2007;48:299-300.
6. Peterson BW and Rupprecht CE. Human Rabies Epidemiology and Diagnosis. In: Tkachev S, ed., Non-Flavivirus Encephalitis. 2011:247-278.
7. CDC. Human Rabies Prevention – United States, 2008. *MMWR* 2008;57:1-28.
8. Briggs DJ, Dreesen DW, Nicolay U, et al. Purified chick embryo cell culture rabies vaccine: interchangeability with human diploid cell culture rabies vaccine and comparison of one versus two-dose post-exposure booster regimen for previously immunized persons. *Vaccine* 2001;19:1055-1060.
9. CDC. Use of a Reduced (4-Dose) Vaccine Schedule for Post-exposure Prophylaxis to Prevent Human Rabies. *MMWR* 2010;59:1-9.
10. Enright JB, Franti CE, Frye FL, Behymer DE. The effects of corticosteroids on rabies in mice. *Can J Microbiol* 1970;16:667-675.
11. Pappaioanou M, Fishbein DB, Dreesen DW, et al. Antibody response to pre-exposure human diploid cell rabies vaccine given concurrently with chloroquine. *N Engl J Med* 1986;314:280-4.
12. CDC. (2009, January 19). Dog bites. Retrieved from <http://www.cdc.gov/HomeandRecreationalSafety/Dog-Bites/index.html>
13. Maine Department of Health and Human Services. 10-144 Chapter 251: Rules Governing Rabies Management, 1998.
14. Murray KO, Holmes KC, Hanlon CA. Rabies in vaccinated dogs and cats in the United States, 1997–2001. *JAVMA* 2009;235(6):691-5.
15. Ohio State University Extension. (1997). Fact Sheet, Rabies Prevention in Livestock. Retrieved from <http://ohioline.osu.edu/vme-fact/0001.html>
16. National Association of State Public Health Veterinarians, Inc. Compendium on Animal Rabies Prevention and Control, 2011.

Additional References

- American Veterinary Medical Association. Report of the AVMA Panel on Euthanasia. *J Am Vet Med Assoc* 2001; 218:5,669-696.
- American Veterinary Medical Association. Wild Animals as Pets. Directory and resource manual. Schaumburg, IL: 2002:126.
- American Veterinary Medical Association. Position on Canine Hybrids. Directory and Resource Manual. Schaumburg, IL: 2002:88-89.
- American Veterinary Medical Association. Model rabies control ordinance. Directory and resource manual. Schaumburg, IL:2002:114-116.
- Bender J, Schulman S, et al. Reports of zoonotic disease outbreaks associated with animal exhibits and availability of recommendations for preventing zoonotic disease transmission from animals

to people in such settings. *J Am Vet Med Assoc* 2004; 224:1105-1109.

Bunn TO. Canine and feline vaccines, past and present. In: Baer GM, ed., *The Natural History of Rabies*, 2nd ed. Boca Raton, FL: CRC Press, 1991:415-425.

CDC. Human Rabies - Michigan, 2009. *MMWR* 2009;60(14):437-440.

CDC. Human rabies prevention-United States, 1999. Recommendations of the Advisory Committee on Immunization Practices (ACIP). *MMWR* 1999; 48:(No. RR-1).

CDC. An imported case of rabies in an immunized dog. *MMWR* 1987, 36:94-96,101.

CDC. Imported dog and cat rabies – New Hampshire, California. *MMWR* 1988, 37:559-560.

CDC. Mass treatment of humans who drank unpasteurized milk from rabid cows-Massachusetts, 1996-1998. *MMWR* 1999; 48:228-229.

CDC. Human Rabies - California, 2002. *MMWR* 51:686-688.

CDC. Human Rabies -Tennessee, 2002. *MMWR* 51:828-829.

CDC. Human Rabies -Iowa, 2002. *MMWR* 52:47-48.

CDC. Human Death Associated with Bat Rabies - California, 2003. *MMWR* 2003;53:33-35.

De Serres G, Dallaire F, Cote, Skowronski DM. Bat rabies in the United States and Canada from 1950 through 2007: human cases with and without bat contact. *Clin Infect Dis* 2008;46:1329-37.

Frantz SC, Trimarchi CV. Bats in human dwellings: health concerns and management In: Decker DF, ed., *Proceedings of the first eastern wildlife damage control conference*. Ithaca, NY: Cornell University, 1983: 299-308.

Greenhall AM. House bat management. US Fish and Wildlife Service, Resource Publication 143, 1982.

Hanlon CA, Childs JE, Nettles VF, et al. Recommendations of the Working Group on Rabies, Article III: Rabies in wildlife. *J Am Vet Med Assoc* 1999; 215:1612-1618.

Hanlon CA, Smith, JS, Anderson, GR, et al. Recommendations of the Working Group on Rabies, Article II: Laboratory diagnosis of rabies. *J Am Vet Med Assoc* 1999; 215:1444-1446.

Hanlon CA, Niezgodna MN, Rupprecht CE. Post-exposure prophylaxis for prevention of rabies in dogs. *Am J Vet Res* 2002; 63:1096-1100.

Heyman DL, ed. Rabies. *Control of Communicable Diseases Manual*, 19th ed. Washington, DC: American Public Health Association, 2008:498-508.

Jackson AC, Fenton MB. Human rabies and bat bites. *Lancet* 2001;357(9269):1714.

Jay MT, Reilly KF, DeBess EE, Haynes EH, Bader DR, Barrett LR. Rabies in a vaccinated wolf-dog hybrid. *J Am Vet Med Assoc* 1994; 205:1729-1732.

McQuiston J, et al. Epidemiologic characteristics of rabies virus variants in dogs and cats in the United States, 1999. *J Am Vet Med Assoc* 2001; 218:1939-1942.

Messenger SL, Smith JS, Rupprecht CE. Emerging epidemiology of bat-associated cryptic cases of rabies in humans in the United States. *Clin Inf Dis* 2002; 35:738-747.

Niezgodna M, Briggs DJ, Shaddock J, Rupprecht CE. Viral excretion in domestic ferrets (*Mustela putorius furo*) inoculated with a raccoon rabies isolate. *Am J Vet Res* 1998, 59:1629-1632.

Rupprecht CE, Blass L, Smith K et al. Human infection due to recombinant vaccinia-rabies glycoprotein virus. *N Engl J Med* 2001; 345:582-586.

Tepsumethanon V, Lumlerdacha B, Mitmoonpitak C, Sitprija V, Meslin FX, Wilde H. Survival of naturally infected rabid dogs and cats. *Clin Infect Dis*. 2004; 39:278-80.

Vaughn JB, Gerhardt P, Newell KW. Excretion of street rabies virus in saliva of dogs. *J Am Med Assoc* 1965, 193:363-368.

WHO Expert Consultation on Rabies: First Report, Geneva:2004.

Appendices

- A. Abbreviations
- B. Rabies Submission Guidelines
- C. Rabies Submission Form
- D. Home Quarantine Notice
- E. Animal Bite Report
- F. Animal Shelter Adoption Disclaimer
- G. Wolf Hybrid Notice
- H. Recommended handling procedures for potentially rabid animal carcasses
- I. Bat Exclusion
- J. NASPHV Form 51, Rabies Vaccination Certificate
- K. Rabies Vaccination Waiver Form
- L. Model Rabies Control Ordinance for Maine Municipalities
- M. Municipalities' responsibility to rabies control
- N. Formulation of rabies prevention policies in animal facilities
- O. Rabies Post-Exposure Prophylaxis Reporting Form

Abbreviations

ACIP	Advisory Committee on Immunization Practices
ACO	Animal Control Officer
ADC	Animal Damage Control Cooperator
Maine CDC	Maine Center for Disease Control and Prevention
DFA	Direct Fluorescent Antibody
HDCV	Human Diploid Cell Vaccine
HETL	Health & Environmental Testing Laboratory
HRIG	Human Rabies Immune Globulin
Maine DHHS	Maine Department of Health and Human Services
IF&W	Maine Department of Inland Fisheries & Wildlife
MRSA	Maine Revised Statutes Annotated
PCECV	Purified Chick Embryo Cell Vaccine
PEP	Post-exposure Prophylaxis
RNA	Ribonucleic acid



Maine Center for Disease
Control and Prevention
An Office of the
Department of Health and Human Services

Health and Environmental Testing Lab
221 State Street, Station 12
Augusta, ME 04333
Tele: 207-287-2727 Fax: 207-587-6832
After hours: 1-800-821-5821

RABIES SUBMISSION FORM

SEND REPORT TO: _____ **Home Tele:** _____

Mailing address: _____ **Work Tele:** _____

City: _____ **State:** _____ **Zip:** _____

ANIMAL TO BE TESTED: Bat Cat Dog Fox Raccoon Skunk
 Woodchuck Livestock species: _____ Other: _____

Animal was from **Town:** _____ **County:** _____

LIVESTOCK USE ONLY: Age (approx.): _____ **Gender:** _____ **Breed:** _____

EXPOSURE INFORMATION: Human Animal Both **EXPOSURE DATE:** _____

SPECIES OF ANIMAL EXPOSED: _____ **Vaccination status:** _____

Owner's Name: _____ **Home Tele:** _____

Mailing address: _____ **Work Tele:** _____

City: _____ **State:** _____ **Zip:** _____

Was the animal BITTEN yes [] no [] describe the exposure and the circumstance of exposure:

HUMAN EXPOSURE (name): _____ **Home Tele:** _____

Mailing/Physical address: _____ **Work Tele:** _____

City: _____ **State:** _____ **Zip:** _____

Was this person BITTEN yes [] no [] describe the exposure and the circumstance of exposure:

FOR HETL USE ONLY:		Lab #: _____
FA Result: _____	Reported by: _____	Date: _____
	Date: _____	Time Rec'd: _____
Results Called To: _____	Date: _____	Entered By: _____
	Time: _____	
	Tech: _____	

GUIDELINES FOR SUBMITTING SPECIMENS FOR RABIES TESTING

I. TESTING CRITERIA

Animals under suspicion of rabies that have potentially exposed a human or domestic animal to its saliva or neural tissue will be accepted for rabies testing as part of statewide surveillance. Members of the public may request rabies testing at a cost of \$150.00 per test. For consultation to determine if testing is necessary for public health purposes, contact the Division of Infectious Disease Epi-on-Call at **1-800-821-5821**.

II. SPECIMEN PREPARATION

1. HETL does not accept live animals with the exception of bats. If a bat requires testing, the entire body may be submitted.
2. With the exception of bats, all animals should be decapitated by veterinarians or trained personnel. Take care to keep the animal's head intact. Always handle the specimen with waterproof gloves and proper protective equipment.
3. If the specimen cannot be transported to HETL immediately, refrigerate the specimen (Do not freeze!).
4. Fresh specimen is required. Rabies testing cannot be performed on decomposed animals.
5. Do not place specimen in formalin.

III. PACKAGING

1. If specimen has sharp protruding parts (i.e., porcupine quills or shattered bones), wrap in several layers of newspaper.
2. Place specimen in two (2) leak proof plastic bags.
3. Place bagged specimen in an insulated container (Styrofoam box) along with refrigerant packs. Neither containers nor animals can be returned. Close container securely with tape.
4. Complete Rabies Submission Form (include complete mailing address) and attach to the container exterior. Note all animals and persons potentially exposed to animal to be tested.
5. Payment of \$150 cash or check made out to "Treasurer of State" must accompany animals when testing is deemed not necessary for public health purposes.

IV. TRANSPORTATION

1. Send specimen by: Personal carrier, UPS, Federal Express.
2. The transportation fee must be pre-paid. The specimen should reach the lab within one day.
3. Specimens may be delivered Monday – Friday, 7:30 am – 5:00 pm. For after-hours delivery, contact Capitol Security (287-4357) for admittance. A phone is available inside the main entrance of the DHHS building at 221 State Street.

V. TEST RESULTS

1. For specimens received by 11:00 am, Monday – Friday, results are available by late afternoon the same day. The primary person ("Send Report to :") listed on the submission form is informed of test results by phone. In the event of a positive test, public health officials act immediately to advise persons involved of necessary measures to prevent the spread of rabies.
2. For specimens received after 11:00 am, results are available the next business day.
3. Urgent requests are handled on a case-by-case basis by calling 1-800-821-5821.

HOME QUARANTINE NOTICE

You are hereby required to confine your animal for [10 days] [6 months] from the date of this notice in compliance with State rules governing rabies management. Pending the animal control officer (ACO) or person acting in that capacity's investigation, this quarantine period could be increased upon further findings. The animal must be kept separate from humans and other animals to observe for signs of rabies and to prevent humans or animals from being exposed.

You must report to the ACO immediately in case the animal shows signs of illness or behavior changes during the quarantine period. The animal may not run at large nor be left outside unsupervised. The animal shall not be taken from the quarantine area except to be transported to a veterinarian for examination or euthanasia and must be under the direct supervision of a responsible adult, on a leash or tether, no longer than six feet. You may not sell, give away, euthanize or otherwise dispose of the animal during the quarantine period. Escaping from quarantine is regarded as a violation of this order, and must be reported to the ACO immediately. If the animal dies during the quarantine period, the ACO must be notified immediately and the animal tested for rabies.

The ACO must be permitted to make periodic observation or examination of the animal at the place of quarantine during the quarantine period. The ACO must visually inspect the animal at the end of the 10-day quarantine period; the animal may still require a veterinary exam. A veterinarian must examine the animal at the end of the 6-month quarantine period. Failure to heed this notice and abide by the restrictions herein given will subject the animal to seizure by the ACO for quarantine at owner's expense at a state licensed boarding kennel or veterinary hospital and will subject the owner to any penalties prescribed by State Law.

Owner Identification or Animal Shelter Identification (if stray)

Name: _____

Address: _____ Telephone: (H): _____
(W): _____

Animal Quarantined At: _____

I have received the quarantine notice and will comply with quarantine.

Date: _____ Owner/Keeper's signature: _____

Animal Identification

Type of Animal: _____ M/F: _____ Breed: _____

Description: _____

Date of most recent rabies vaccination: _____ Veterinarian: _____

Animal Control Officer

Animal Observe Dates: _____

Signature: _____

ANIMAL BITE REPORT (page 1 of 2)
(to be filed with municipality records)

Date: _____ Case #: _____

Town in which report is to be filed: _____

VICTIM IDENTIFICATION (If human contact)

Name: _____ DOB: _____ M [] F []

Address: _____ Telephone (H) _____ (W) _____

If minor, parent/guardian: _____ Relationship: _____

Address, if different: _____ Telephone (H) _____ (W) _____

Did victim have rabies prevention immunizations prior to this incident? Yes [] No [] Unknown []

DOMESTIC ANIMAL IDENTIFICATION (IF ANIMAL CONTACT)

Type of Animal: _____ Owned [] Stray [] Wild []

Description: _____ M [] F [] Age: _____

If owned – owner/keeper: _____ Telephone (H) _____ (W) _____

Address: _____

Date of most recent rabies vaccination: _____ Veterinarian: _____ Telephone: _____

License #: _____ State: _____ Clinic: _____ Tag # _____ Exp. _____
(Rabies) (Date)

SUSPECT ANIMAL

Type of Animal: _____ Owned (If Applicable) () Stray () Wild ()

Description: _____ M () F () Age (If known): _____

If owned – owner/keeper: _____ Telephone: _____

Address: _____

Date of most recent rabies vaccination: _____ Veterinarian: _____ Telephone: _____

License #: _____ State: _____ Clinic: _____ Tag # _____ Exp. _____
(Rabies) (Date)

ANIMAL BITE REPORT (page 2 of 2)

DESCRIPTION OF INCIDENT

Date reported: _____ Reported by: _____

Date of Incident: _____ Type of contact: Bite Scratch Other (specify): _____

Body part(s) bitten/scratched: _____ Medical care required? Yes No

Hospital: _____ Doctor: _____

Was rabies post-exposure prophylaxis given to victim? Yes No Unknown

Date that post-exposure prophylaxis was initiated: _____

Where did incident take place? _____ Provoked? Yes No

Description of incident: _____

DISPOSITION OF VICTIM ANIMAL

In owner's possession: Euthanized and sent to HETL for testing: Unknown (not captured):
Veterinary Hospital: Animal Shelter: Boarding Kennel: Other (specify): _____

Name of facility & location: _____

Telephone: _____ Date of quarantine: _____ Date of release: _____
Veterinary exam? Yes No

DISPOSITION OF SUSPECT ANIMAL

In owners possession: () Euthanized and sent to HETL for testing: () Unknown: () Not captured: ()
Veterinary hospital: () Animal shelter: () Boarding kennel: () Other (specify): _____

Name of facility & location: _____

Date of quarantine: _____ Date of release: _____ Veterinary exam? Yes () No ()

INVESTIGATING OFFICER

Name (print): _____ Signature: _____

Title: _____ Employer: _____

Address: _____

Enforcement: Rabies Advisory Notice Quarantine Notice Civil/Criminal Summons

Other: _____

Has animal been ill, acted strangely, or bitten anyone recently? Yes No

If yes, explain: _____

Animal Shelter Adoption Disclaimer:
YOUR NEW PET AND RABIES

A dog, cat or other animal which has been bitten by or exposed to a rabid animal may not develop symptoms of rabies for up to six months. During this time (the incubation period), the exposed animal may appear to be totally healthy. Since the vaccination history of stray and abandoned animals is usually unknown, many of these animals have not had prior protection for rabies. Although all dogs and cats have been carefully screened for signs of exposure to rabid animals prior to adoption, the possibility still exists that your adopted pet could develop rabies. Therefore, it is very important for you to know that these symptoms in your pet could be rabies: change in behavior, vicious or nervous activity, difficulty swallowing, excessive drooling, difficulty walking or paralysis. If your adopted pet develops any of these symptoms, immediately separate it from humans and other animals and have it examined by a veterinarian.

Newly adopted pets should be examined by a veterinarian and vaccinated if they have not been. However, a rabies vaccination will not protect the animal from previous bites or other prior exposures to rabies.

I have read this statement and will not hold the _____
_____ Shelter responsible should my adopted pet
develop rabies.

Signed: _____

Date: _____

ATTENTION WILDLIFE HYBRID OWNERS

If your wildlife hybrid bites a person or domesticated animal, it will be euthanized at your expense and tested at the Health and Environmental Testing Laboratories for rabies as soon as possible.

There is no rabies vaccine approved for use in a wildlife hybrid dog. Although your veterinarian may vaccinate your hybrid, it is unknown whether or not the vaccine provides any protection. Unlike with dogs, cats and ferrets, there is no known period during which a wildlife hybrid can be confined and observed for purposes of assessing whether the animal exhibits signs of rabies infection.

Examination of brain tissue is the only acceptable means of testing for the presence of rabies virus in a wildlife hybrid.

Maine Department of Health and Human Services



RECOMMENDED HANDLING PROCEDURES FOR POTENTIALLY RABID ANIMAL CARCASSES

Since it is possible for rabies to be transmitted from infected animal carcasses, the following steps are recommended when handling the carcass of any animal that has the potential to be rabid.

1. Whenever possible, use a shovel to pick up the carcass. If you must use your hands, use barrier protection such as heavy-duty rubber gloves. If at all possible, avoid touching any wet area on the carcass. However, if the gloves or shovel become wet with bodily fluids, allow them to dry before touching with bare hands. If there is any rabies virus still alive in the animal carcass, the virus will die when it dries.
2. If the gloves or shovel need to be disinfected immediately, use a bleach or bleach and water solution. Remember however, that once bleach is mixed with water, it begins to become inactive and after 24 hours is no longer considered to be a proper disinfectant.

DISPOSAL OF ANIMAL CARCASSES

Animal carcasses that pose a physical, health or safety hazard should be removed and disposed in an appropriate manner. Carcasses which may be associated with rabies, distemper, or other potentially contagious diseases should receive special consideration to avoid unreasonable contamination or exposure to humans or pets. Animal carcasses should never be disposed of in trash cans or dumpsters. Incineration, burial or appropriate surface disposal may be employed as outlined below.

SINGLE ANIMAL BURIAL:

Disposal of single, small animal carcasses should be based upon location of the carcass.

1. In areas where the carcass is likely to be encountered by humans or their pets, it should be disposed of by incineration or burial. There are no setback or soil condition requirements for small, single animal burials, but you should avoid wet areas, shallow to bedrock areas or areas very close to water bodies for the burial site. Carcasses should be placed in an excavation, no more than two feet deep, and covered by at least 18 inches of soil to prevent the carcasses from being dug up by another animal.
2. For remote areas, where human or pet contact is unlikely and the rabies threat is minimal, placing the carcass in the woods is an acceptable option. Caution and professional judgment should be exercised when determining whether or not placement is an acceptable disposal method.
3. To transport a potentially rabid animal carcass, use a heavy duty plastic bag such as a bio-hazard bag. If disposal is to be by burial, do not bury the bag along with the carcass. It will not decompose or allow the carcass to decompose. After the carcass has been properly disposed of, carefully place the contaminated bag inside another, clean, plastic bag. Tie the outside bag tightly and then dispose of it in a proper manner (dumpster, trash can etc.). Be careful not to dispose of the bags in a place likely to be searched by persons for returnable bottles or where children frequently play.

PROCEDURE FOR BURIAL OF UP TO 500 LBS. PER YEAR OF CARCASSES IN ACCORDANCE WITH MDAFRR RULES AND POLICY; EFFECTIVE DATE: SEPTEMBER 16, 1996

1. Select a site which is in an upland position, without a large watershed and which typically does not have a high seasonal water table.
2. Excavate a trench which is three feet or less wide and 18 inches deep. The bottom of the trench must be at least 24 inches above bedrock. Trenches must follow the contour so that the bottom of the trench is level.
3. Carcasses must be placed in the trench to a thickness of no more than 12 inches, limed, and covered with a minimum of 18 inches of fill. The fill surface should be loamed and seeded.
4. Additional trenches may be used if separated by a minimum of three feet, edge of trench to edge of trench.
5. Burial sites must meet the following minimum setback distances, unless a variance is granted by the department:

<u>FEATURE</u>	<u>SETBACK DISTANCE</u>
Perennial (year round) Waterbodies	150'
Intermittent (seasonal) Waterbodies	75'
Public Water System	300'
Private Wells (not owners)	300'
Private Wells (owners)	100'
Roads	50'
Buildings (not owners)	
*Residences	100'
*Non Residences	50'
Buildings (owner)	20'
Property Lines	50'
Significant Sand and Gravel Aquifers	Not Within
10 Year Flood Plain	Not Within
Slopes	15% or less

If you should have any questions, please contact the Maine Department of Agriculture, Food and Rural Resources, Office of Agricultural, Natural and Rural Resources, State House Station #28, Augusta, Maine 04333. Phone: (207) 287-1132.

LARGE VOLUME BURIAL SITES:

Large numbers of carcasses (more than 500 lbs. per year) should be disposed of in accordance with Chapter 211 – Rules for the Disposal of Animal Carcasses, administered by the Maine Department of Agriculture, Food and Rural Resources, when a single burial site is to be used. These Rules also outline appropriate incineration procedures and other disposal methods.

BAT EXCLUSION

Most bats are healthy and contribute to our environment in many ways, particularly by consuming insect pests. Less than 0.5 % (1 out of 200) of bats randomly sampled are positive for the rabies virus. One rabid bat in a colony does not mean the entire colony is infected. Testing other members of the colony rarely results in finding another rabid bat.

Bat rabies is generally independent from rabies in terrestrial mammals, but transmission from bats to other wildlife, unvaccinated domestic animals and humans can occur. Bat rabies strains have been found in grey foxes, domestic cats and livestock in areas, which were otherwise free of terrestrial animal rabies. In those cases, the virus detected in the infected animal was the bat rabies virus.

There is no evidence that bats can transmit rabies for an extended period without being ill. Bats, like other mammals, become sick and eventually die from the disease. Bats infected with rabies may have the virus in their saliva and may transmit the disease to humans and other animals. This type of exposure most commonly occurs through a bite.

Rabid bats may show abnormal behavior, such as extended outdoor activity during daylight; rabid bats may be grounded, paralyzed or may bite a person or animal. Not all rabid bats act abnormally, but bats that do are more likely to have rabies. Rabid bats rarely attack humans. But, because rabies can occur anywhere and because rabies can be fatal, any contact with bats should be strictly avoided. Each contact with a bat should be managed by health authorities.

Unnecessary killing of bats is neither an environmentally sound, humane, nor permanent solution. Using chemicals or pesticides creates a risk of long-term toxic exposure to humans and causes sick or dying bats to be grounded in the community, further increasing the chance of contact with people and pets. No toxicant is legally registered for use against bats.

Bats should be kept out of places where there is a high risk of contact with humans or pets (for example, schools, hospitals, prisons, and homes) by closing or covering openings that allow entry to the roost. There are many sources of information, including the Internet, libraries, and professional exterminators/contractors, on “bat proofing” your home.

The following is modified from *Bats in Buildings: An Information and Exclusion Guide*, by Barbara French, Laura Finn, and Mark Kiser. It is available from Bat Conservation International, Inc., at www.batcon.org.

Introduction

As primary predators of night-flying insects, bats play a vital role in maintaining the balance of nature. A single little brown bat can catch 1,200 mosquito-sized insects in an hour, and big brown bats are important predators of some of America's most costly crop pests. Cucumber beetles, June beetles, bark beetles, stink bugs, leafhoppers, cutworm moths, corn earworm moths, armyworm moths, termites, assassin bugs, ants, roaches, crickets, and grasshoppers are just some of the many pests known to be consumed by America's bats. Yet, bat populations are in alarming decline due to a disease called White-Nose Syndrome (WNS).

WNS has caused precipitous declines in bat populations in the Northeast over the past several years. Bats in the genus *Myotis* have been particularly hard hit, it is estimated that more than 5 million bats in the North America have died due to WNS. Models predict that the little brown bat may face extinction by 2026 if current trends continue.

To help protect bat populations affected by WNS, the Maine Department of Inland Fisheries and Wildlife is asking private property owners and Animal Damage Control Officers **not** to exclude bats from roosting sites (i.e., attics, barns) until **after August 15th**. After this date the young born in the summer will be able to escape the space with their mothers and not be left behind to die.

As traditional roosts in trees and caves have been destroyed, many of North America's bats have been forced to seek shelter in man-made structures. An understanding of the habits of these beneficial animals can help solve problems that sometimes develop when bats roost in buildings. The following pages provide details about safe, effective methods for permanently evicting bats from buildings when necessary. These methods help ensure the safety of both humans and bats.

Accidental Intruders

What if you find a bat in your home?

On occasion, a solitary bat may accidentally fly into a home, garage or other building through an open door or window. Such incidents often involve lost youngsters whose primary goal is a safe escape. These bats will usually leave on their own if a window or door to the outside is opened while others leading to the rest of the building are closed –**do NOT allow the bat to escape if there was any possibility of contact between the bat and a human or pet.** Bats are rarely aggressive, even if chased, but may bite if handled. As with any wild animal, bats should not be touched with bare hands, and anyone bitten should immediately

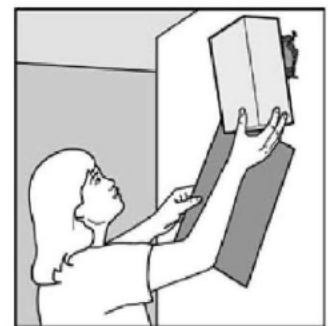
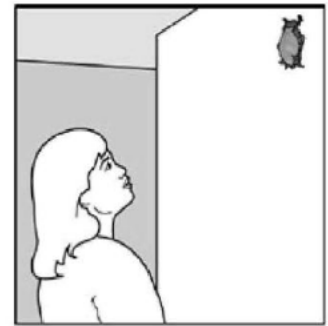

seek medical consultation.

Only animal control officers, game wardens, or pest management personnel should capture live bats. If a citizen must capture a bat that may need to be tested for rabies, the following technique should be utilized (**damaging the bat's head should be avoided as it may prevent a rabies testing from being performed**): 1) use caution and avoid direct contact with the bat; wear leather gloves if possible, 2) wait until it lands, and then cover it with a small box, coffee can, or other container; 3) slip a piece of cardboard under the container, thus trapping the bat, 4) secure the bat by taping the cardboard tightly to the container, 5) wash your hands with soap and water, and 6) call your local animal control officer, game warden, or pest management personnel to assist in arranging for rabies testing of the bat at the State's Health and Environmental Testing Laboratories in Augusta.

If, after consultation with public health, it is determined that was no human or domestic animal exposure to the bat, then slip a piece of cardboard between the wall and box, slide the bat into the box, then release the bat outside. You may also catch it by hand, using leather work gloves to avoid being bitten. Keep doors and windows to buildings closed, and window screens in good repair, to prevent bats from reentering.

Where do bats roost?

Bats may roost in attics, soffits, louvers, chimneys, under siding, eaves, roof tiles or shingles and behind shutters (see diagram). In sports stadiums and parking garages, bats sometimes roost in expansion joints between concrete beams. They can enter through openings as small as one-half inch in diameter (1.3 cm). Common points of entry include open windows or doors, broken or poorly-fitted screens, loose or missing shingles or tiles, places where flashing or boards have come loose and locations where pipes or wiring enter buildings. Openings often occur where walls meet the eaves at the gable ends of an attic, where porches attach to the main part of a house, or where dormers meet the roof. Other points of entry are associated with siding. For example, cracks and crevices are often created where siding forms corners, or at places where it meets windows, doors or chimneys (see diagram). Bats can sometimes be detected by the presence of black or brown stains from body oils or droppings around cracks or crevices formed by ill-fitting building materials. Bat droppings may also appear on walls, under porches or decks, or on floors beneath dilapidated ceilings. Bat droppings are dark and do not contain any white material. Although they may resemble small hard rodent pellets, bat droppings are soft and easily crushed, revealing shiny insect parts.



Common entry points on homes and buildings include corners, eaves and louvers.

Providing a safe exit for bats

There is little reason to evict bats from buildings where they are not causing a nuisance. However, bats should be prevented from entering human living quarters. This can be accomplished by inspecting the inside of a building for small openings through which bats could enter. All openings connecting the attic or other roosting areas to inside living quarters should be sealed, although entry points on the outside of the building should be left open, allowing bats to exit. Draft-guards should be placed beneath doors to attics; electrical and plumbing holes should be filled with steel wool, caulking or weather stripping. Bats have small teeth for eating insects; they do not gnaw through wood or other building materials like rodents. Caulking, flashing, screening or insulation can be used to seal most openings on the inside. Expanding urethane foam products should not be used to seal cracks where bats are active, because they can become caught in it. Caulk should also be applied early in the day so that it has time to dry before bats emerge in the evening.

In some instances, noise or odors from large colonies of bats can become a nuisance. When bats must be evicted from a building, netting or tubes that function as one-way valves must be placed over the openings bats use to enter and exit. These one-way valves allow bats to leave, but not reenter the building. Valves may be constructed from lightweight plastic netting (1/6 inch-0.4 cm-or smaller mesh), or plastic pipes or tubes. These exclusion devices should be left in place for five to seven days to ensure all bats have exited. It is not appropriate simply to wait for bats to fly out at night and then seal openings. Not all of the bats leave at the same time, and some bats may remain inside all night. Take weather conditions into consideration when deciding how long to leave the netting or tubes in place; there may be evenings (such as during storms), when no bats exit.

Bats often roost in buildings seasonally, including during maternity periods, and exclusions should not take place until young bats are able to fly. After the young are old enough to fly, all bats can be excluded. The maternity season begins as early as mid-April in the southernmost U.S., mid-June in the northern U.S. and Canada. Young bats are flying and exclusions can resume by late August. In late fall most house-dwellings bats either migrate to warmer climates or enter caves or abandoned mines to hibernate. However, a few species can hibernate in buildings, and in the mildest climates, they may even remain active year-round. If bats are present in cold regions during the winter, exclusions should be postponed until spring when they emerge to feed.

Exclusion is the **ONLY** effective solution for permanently removing bats from buildings. Trapping and relocating is ineffective since bats have excellent homing instincts and simply return, even when released at great distances. The use of pesticides against bats is illegal and counterproductive. Poisoning greatly increases the likelihood of bats coming into contact with people and pets.

Naphthalene, the active ingredient in moth balls, and ultrasonic devices are often promoted as bat repellents. However, ultrasonic devices are ineffective against bats, and to be effective, naphthalene must be used in such large quantities that it poses a significant health hazard to humans.

Using Netting to Exclude Bats

Bats sometimes enter buildings through openings on smooth surfaces of exterior walls or through louvers. In such cases, plastic or lightweight, flexible netting with 1/6 inch (0.4 cm) mesh or smaller, should be secured to the building along the top and sides of the opening as shown in the diagram. It should extend 18 to 24 inches (46 to 61 cm) below the bottom edge of the opening and should remain in place for a minimum of five to seven days to ensure all bats have exited. Then, openings should be permanently sealed with silicone caulking, caulk backing rod, hardware cloth, or heavy-duty netting. In some cases, sealing may require repair or replacement of old, deteriorated wood. When bats are using multiple openings to exit and enter, exclusion material should be placed on each opening unless it can be determined with certainty that all areas used by the bats are connected. If so, some openings can be sealed as described above, and netting can be placed over the openings used by the most bats. Even when all roosting areas are connected, bats will sometimes refuse to use alternative exits. In this case, exclusion material must be installed over all exits. After this has been done, watch to make sure the bats are able to exit safely. If they do not appear to be exiting, or appear to be having trouble doing so, make adjustments or add new valves as needed.

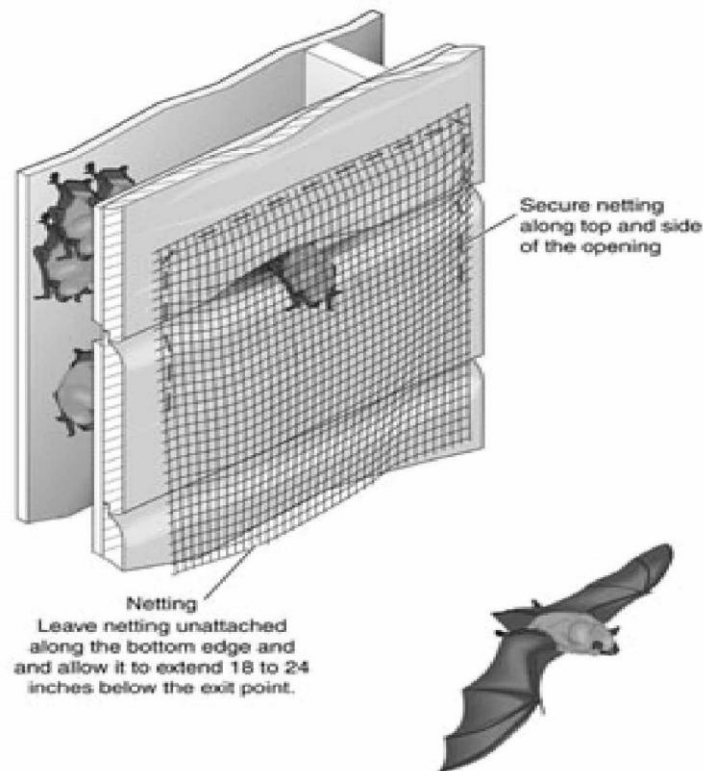

Using PVC pipe or Empty Caulking Tubes to Exclude Bats

There are a number of situations in which tubes work best as bat exclusion devices. Examples include openings used by bats on buildings constructed from materials that do not create smooth exterior walls, such as those found on brick or stone houses, and log cabins. Tubes also work best for holes located at corners where walls meet and on horizontal surfaces such as soffits. Exclusion tubes should have a 2-inch (5 cm) diameter and be approximately 10 inches (25.4 cm) in length. Exclusion devices can be made from PVC pipe or flexible plastic tubing. According to Laura Finn of Fly by Night, Inc., empty caulking tubes work well for this purpose. When using caulking tubes, both ends must be cut out. Use of a flexible plastic tube makes it easy to either

squeeze one end of the tube so that it fits into a crevice, or cut one end of the tube into flaps that can be fit over an opening and stapled, nailed, or taped to the building (see diagram). Bats are unable to cling to the smooth surface of these tubes. Do not let the tube project more than 1/4inch (6 mm) into the opening, ensuring that bats can easily enter the tube to exit. Caulking tubes must be thoroughly cleaned before use to prevent bats from sticking to wet caulk and because dried caulk creates a roughened surface, making it possible for bats to re-enter. Once the tube has been inserted over the hole, a piece of light weight, clear plastic can be taped around the end of the tube that projects to the outside (see diagram) to further reduce the likelihood of bats reentering, though this is typically not necessary.

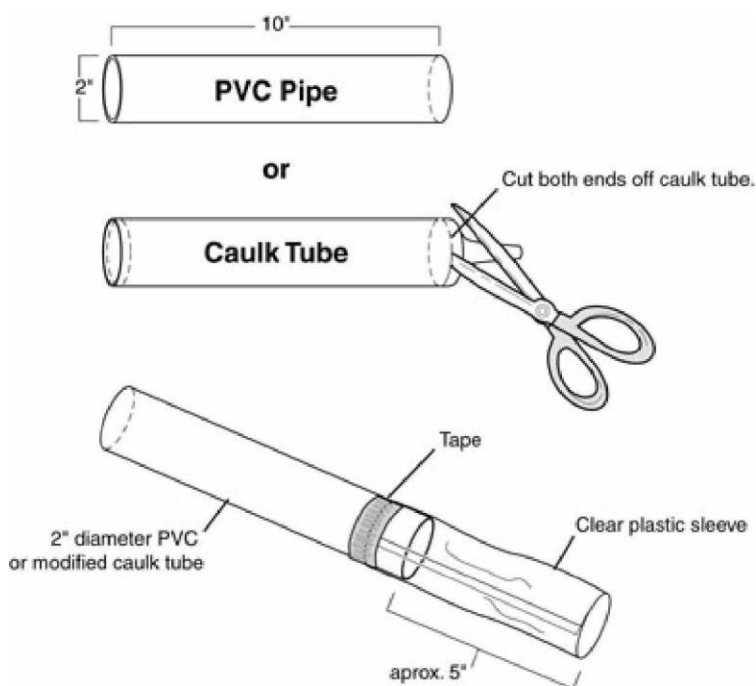

Plastic sleeves collapse on themselves, preventing bats from reentering once they have crawled out through the tube. After the tube has been inserted into or over the opening used by bats, any spaces between the outer rim of the tube and the building must be sealed shut. Be sure also to seal shut any other openings in the building that bats could use to reenter. Leave the tube in place for a minimum of five to seven days to ensure all bats have exited. After the bats have been excluded, the tube should be removed and the opening permanently sealed.

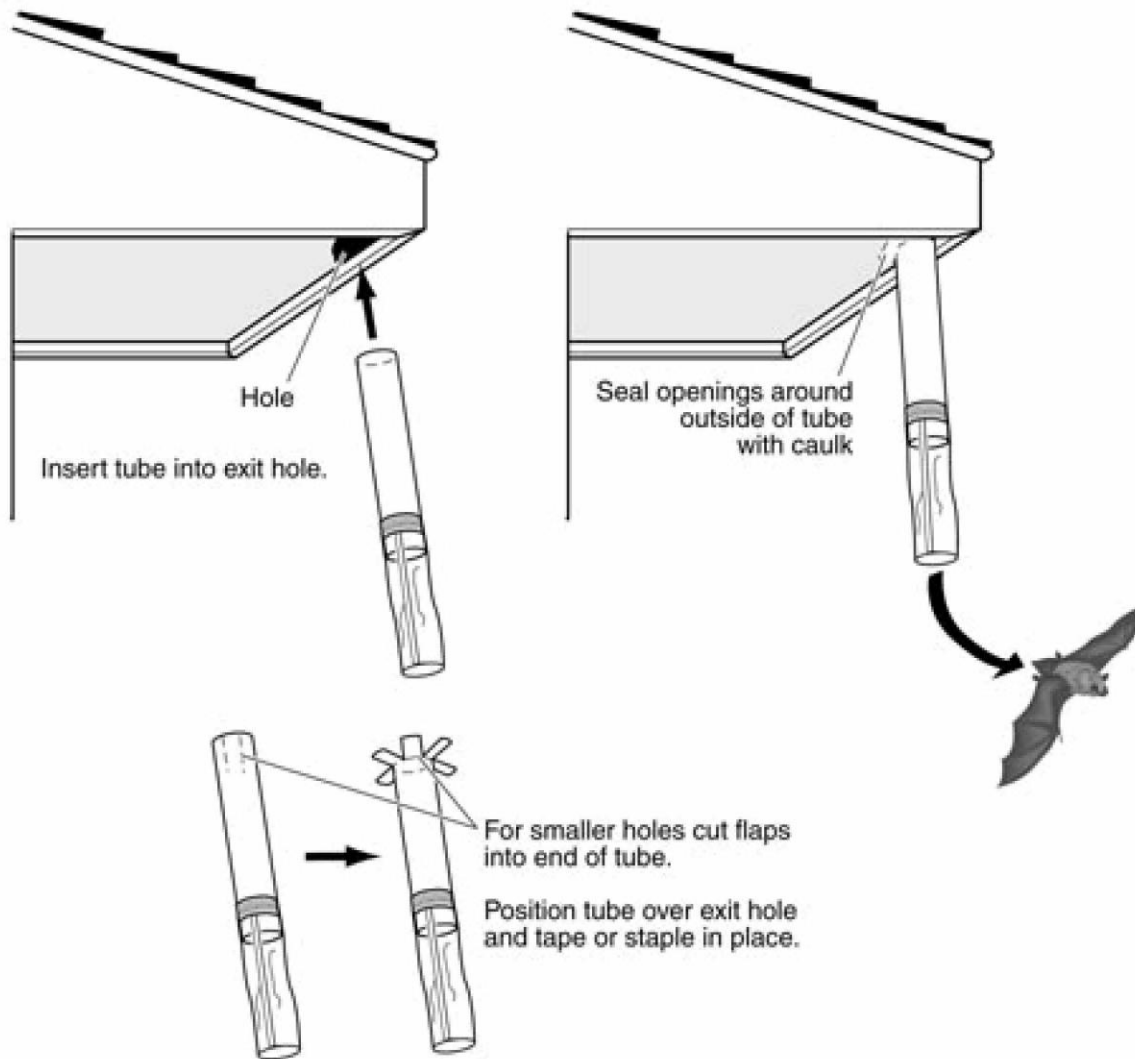

Some concrete parking garages have lengthy crevices used by bats. Multiple exclusion tubes will need to be placed every few feet along the length of each crevice; spaces between the tubes should be closed with heavy-weight (1/6 inch mesh) netting (see diagram). Fold the netting so that it fits into the crevice, and caulk it in place as shown in the diagram. The same procedure can be used in lengthy crevices created where flashing has pulled away from a wall.

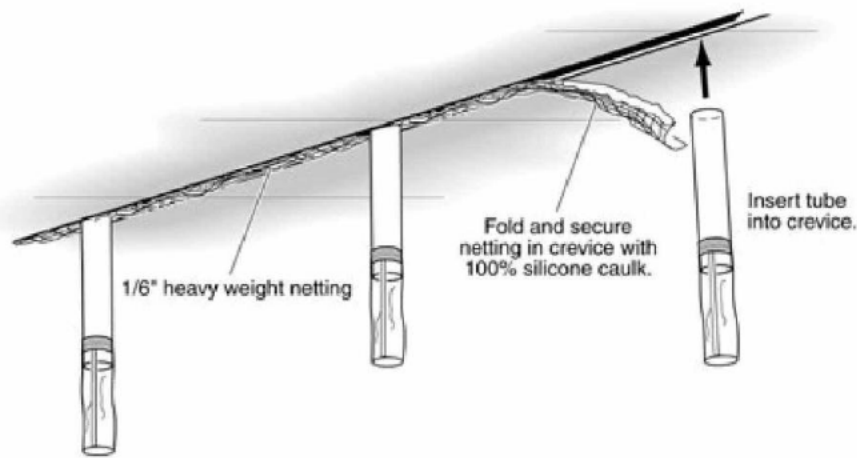

Plastic tubes also work best for excluding bats from under Spanish (clay) or concrete roofing tile. Bats typically enter through open ends of the tiles on the lowest row, or through openings created where tiles overlap one another. Observe the building when bats fly out in the evening to determine which openings they use. Exclusion tubes should be placed in these openings (see diagram). Multiple exclusion tubes are often needed to exclude bats from problem roofs. Collapsible plastic sleeves should also be attached to the ends of the tubes. Heavy weight netting can be folded and inserted into openings where tiles overlap (see diagram).

Tiles are sometimes temporarily removed to replace a layer of tar paper. When this is done, a layer of coarse fiberglass batting can be put over the tar paper and under the tiles. Constantine (1979) found that the fiberglass layer repelled bats, although he recommended against use of batting within 6 inches (15 cm) of open tile ends to prevent birds from pulling it out for nesting material.

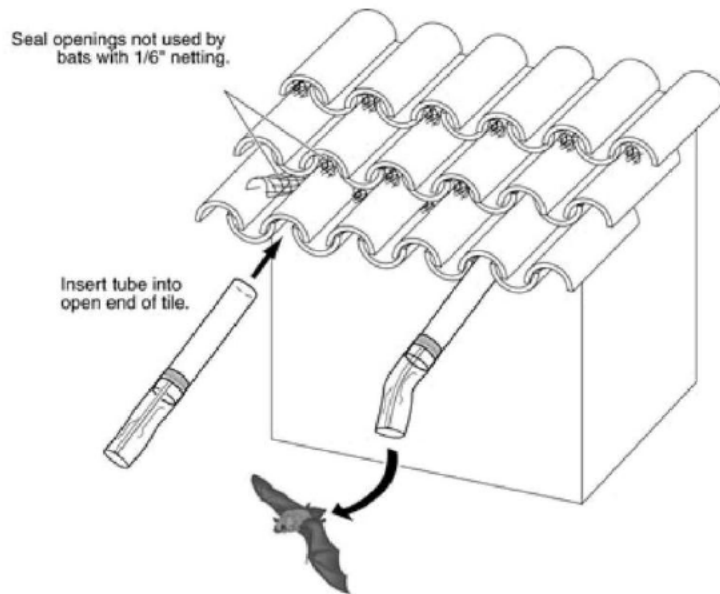

Bats may also enter a building through spaces beneath corrugated or galvanized roofing sheets. These roofs can be sealed with a variety of materials such as caulk backing rod during months when bats are not present, or after they have been excluded from a building by use of exclusion tubes.

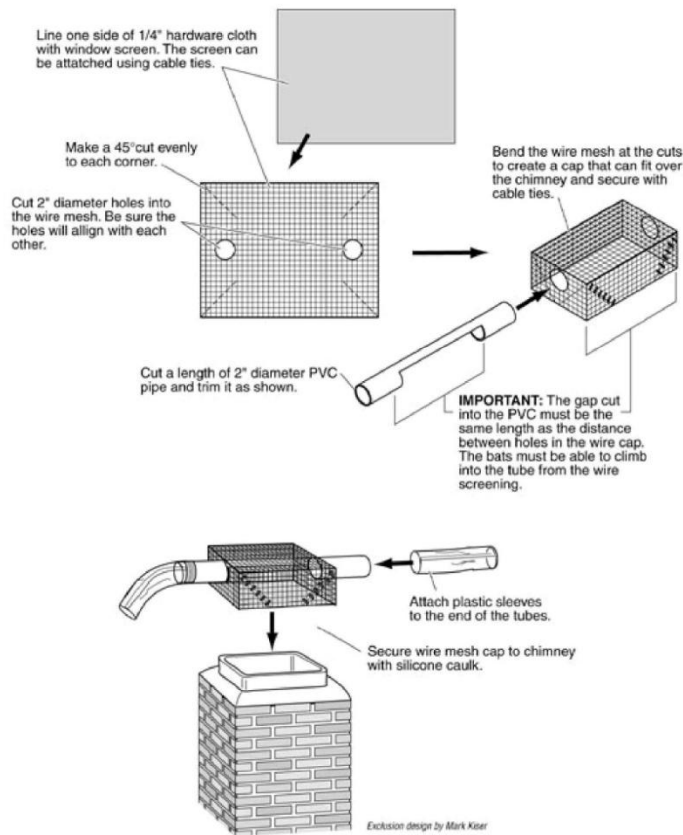

Special modifications may be needed when bats roost in chimneys or in separations between chimneys and roofs. If bats are roosting inside the chimney, construct a wire cage from 1/4-inch hardware cloth lined with window screen. A section of PVC pipe can be cut and then inserted through holes cut into the sides of the wire cage (*see diagram*). Although bats are able to simply drop down and out of a vertically placed tube that extends below the roost, they are not able to grip the slick surface to crawl out if the tube extends upward above the roost. Therefore, the tubes should project horizontally or down. A collapsible plastic sleeve should be placed over the ends of all exclusion tubes used on chimneys. Once the bats have been excluded, a chimney cap should be installed.

Bats Roosting on Porches at Night

Bats sometimes roost on porches or under overhangs briefly during the night while they digest the insects they have eaten. Non-toxic aerosol dog or cat repellents may be used to discourage bats from roosting in these areas. The spray should be applied by day when bats are not present (Aerosol repellents are not an adequate substitute for exclusion in the case of day roosts and should never be applied when bats are in a roost.) Mylar balloons or strips of aluminum foil hung from the porch ceiling and allowed to move in the breeze may also discourage bats from roosting in that area.

Bat Houses

It's always a good idea to provide bats with a new place to roost. For information on building or purchasing bat houses visit the North American Bat House Project Web site at www.batcon.org/bhra.

RABIES VACCINATION CERTIFICATE
NASPHV FORM 51 (revised 2007)

Owner's Name & Address Print Clearly LAST FIRST M.I.			RABIES TAG # <hr/> MICROCHIP #				
NO. STREET			TELEPHONE # <hr/> CITY STATE ZIP				
SPECIES Dog <input type="checkbox"/> Cat <input type="checkbox"/> Ferret <input type="checkbox"/> Other: <input type="checkbox"/> _____ (specify)	AGE _____ Months <input type="checkbox"/> Years <input type="checkbox"/> SEX <input type="checkbox"/> Male <input type="checkbox"/> Female <input type="checkbox"/> Neutered	SIZE Under 20 lbs. <input type="checkbox"/> 20 - 50 lbs. <input type="checkbox"/> Over 50 lbs. <input type="checkbox"/>	PREDOMINANT BREED _____ <hr/> ANIMAL NAME _____ <hr/> _____	PREDOMINANT COLORS/MARKINGS _____ <hr/> _____ <hr/> _____			
Animal Control License <input type="checkbox"/> 1 Yr <input type="checkbox"/> 3 Yr <input type="checkbox"/> Other _____							
DATE VACCINATED <hr/> Month / Day / Year	Product Name: _____ Manufacturer: <table border="1" style="display: inline-table; border-collapse: collapse; width: 60px; height: 20px;"><tr><td> </td><td> </td><td> </td></tr></table> (First 3 letters) <input type="checkbox"/> 1 Yr USDA Licensed Vaccine <input type="checkbox"/> 3 Yr USDA Licensed Vaccine <input type="checkbox"/> 4 Yr USDA Licensed Vaccine <input type="checkbox"/> Initial dose <input type="checkbox"/> Booster dose					Veterinarian's Name: _____ <hr/> License Number: _____ <hr/> Veterinarian's Signature Address: _____ <hr/> _____ <hr/> _____	
NEXT VACCINATION DUE BY: <hr/> Month / Day / Year	_____ Vaccine Serial (lot) Number						



STATE OF MAINE
DEPARTMENT OF AGRICULTURE
Division of Animal and Plant Health
28 STATE HOUSE STATION
AUGUSTA, MAINE 04333-0028



ANNUAL RABIES VACCINATION WAIVER FORM

Vaccinating domesticated animals against rabies both protects the individual animal against a virtually 100% fatal disease and also provides a crucial barrier between humans and wild animals that might carry rabies. Modern rabies vaccines are considered very safe and have a low incidence of adverse effects. However, some animals might require a waiver of rabies vaccination because the vaccination poses an unacceptably high risk to the health of the individual animal. Maine law permits practicing veterinarians to issue such a waiver under certain circumstances.

Patient Information:

Patient Name: _____ Age: _____ Date of birth: _____
 Species: Cat Dog
 Breed: _____ Sex: Male Female
 Sexually intact? Yes No
 Weight: _____ Colors: _____
 Microchip? Yes If yes, microchip number _____ No
 Microchip Manufacturer: _____
 Tattoo? Yes If yes, describe: _____ No

Owner Information:

Owner Name: _____ Phone: _____
 Street Address: _____
 City, State, Zip: _____
 Email address: _____

Veterinarian Information:

Name: _____ State veterinary license #: _____
 Date of request (mm/dd/yyyy): _____
 Practice or Facility Name: _____
 Street Address: _____
 City, State, Zip: _____
 Phone: _____ Fax: _____
 Email address: _____

Medical History of Animal:

Explicit reason for requesting rabies vaccination waiver (attach additional sheet if required):

Dates of diagnosis: _____

This form has been adapted from and approved by the American Veterinary Medical Association, 1/26/2012.



STATE OF MAINE
DEPARTMENT OF AGRICULTURE
Division of Animal and Plant Health
28 STATE HOUSE STATION
AUGUSTA, MAINE 04333-0028



Rabies Vaccination History:

List all previous rabies vaccinations given. Specify **date(s)** of vaccination, **type(s)** of vaccine given and the **manufacturer(s)** of the vaccine (attach additional sheet if required):

Adverse Event Reporting:

Per the AVMA policy entitled "Reporting Adverse Events," veterinarians are encouraged to report adverse events. If the rabies vaccination waiver is being requested due to a previous adverse event experienced by the animal due to a rabies immunization, has the event been reported to the:

USDA Center for Veterinary Biologics (CVB), 1-800-752-6255?

Yes Date of report to USDA: _____

No

Product manufacturer: Yes Date of report to manufacturer: _____

No

I have examined the animal above and determined that, in my professional opinion, there is considerable risk of harm to the animal from the administration of a rabies vaccine as required by law.

Signature of Veterinarian _____ Date _____

Optional supporting documentation:

Animal Owner's Acknowledgment

By signing below, I acknowledge that I am the owner of the animal described above and that I have been informed of the following:

- This waiver is only effective until one year from the date indicated below, and that I will need to submit a new request every year, which may or may not be granted.
- I should minimize the risk of the animal becoming exposed to rabies by keeping it on my premises or on a leash at all times and minimizing exposure to other animals, especially wild animals. If exposed to a potentially rabid animal, euthanasia of my pet may be required.
- A waiver from rabies vaccination does not exempt the animal from Maine rules or laws related to rabies. If this animal is potentially exposed to rabies, or if the animal bites a person, public health authorities may require that the animal be quarantined and observed for signs of rabies, or euthanized immediately and tested for rabies.

Signature of Owner _____ Date _____

This form has been adapted from and approved by the American Veterinary Medical Association, 1/26/2012.

MODEL RABIES CONTROL ORDINANCE FOR MAINE MUNICIPALITIES
(Adapted from American Veterinary Medical Association's Model Rabies Control Ordinance)

Section I - Definitions

For the purpose of this ordinance, the following definitions shall prevail:

- A. Animal - any of the order *Mammalia*, all of which are capable of being infected with and transmitting rabies.
- B. Cat - any domestic feline animal (*Felis catus*).
- C. Dog - any domestic canine animal (*Canis familiaris*).
- D. Bite or Bitten - means that the skin has been penetrated by an animal's teeth.
- E. Isolation - confinement of an animal exposed or potentially exposed to rabies.
- F. Non-bite Exposure - means that saliva from an animal has come in contact with an open wound or a mucous membrane.
- G. Own - to keep, harbor, or have control, charge, or custody of an animal.
- H. Owner - any person who keeps, harbors, or has charge or control of, or permits any animal to habitually be or remain on, or be lodged or fed within his or her house, yard, or premises. This term shall not apply to veterinarians or kennel operators who have temporary custody, for a period of less than 60 days, of animals owned by others.
- I. Animal Shelter - a public facility that is maintained by a government entity, or a private facility providing contractual services to a government entity for the purpose of impounding or harboring animals.
- J. Quarantine - the strict confinement of an animal in a manner which precludes direct contact with other animals not concurrently in quarantine or persons other than the owner or caretaker. The quarantine shall be conducted under an order issued by the Public Health Official or the Rabies Control Authority designating the specific place, manner and provisions of the quarantine.
- K. Rabies Control Authority - a government agency or persons who are legally authorized and responsible for enforcement of this ordinance.
- L. Currently Vaccinated Against Rabies describes an animal that has received a primary rabies vaccine no less than 28 days previously, or has received a booster vaccine, administered in accordance with the current *Compendium of Animal Rabies Prevention and Control* prepared and updated annually by the National Association of State Public Health Veterinarians. Rabies vaccination must be performed by or under the direct supervision of a veterinarian who is licensed or legally permitted to practice veterinary medicine in the state.

Section II - Rabies Vaccination Requirements

- A. Initial Vaccination:
Effective _____ in the (city, town, village, or county) of _____, the owner of every dog or cat 3 months of age or older shall have the animal vaccinated against rabies. Vaccination at a younger age should be in accordance with the labels of USDA licensed rabies vaccines. Unvaccinated dogs and cats more than 3 months of age that are acquired or moved into the (city,

town, village, or county) must be vaccinated within 30 days of purchase or arrival, unless there is documented evidence of current vaccination.

- B. Revaccination: The owner of every dog or cat shall have the animal revaccinated 12 months after the initial vaccination. Thereafter, the interval between revaccinations should conform to the manufacturer's written instructions (every 12 months for annual vaccines and every 36 months for triennial vaccines).

Section III - Duties

- A. Duties of Veterinarian It shall be the duty of each veterinarian, when vaccinating any dog or cat to complete a certificate of rabies vaccination (or generate a computer printout) for each dog or cat that is vaccinated. The certificate shall include the following information:

1. Owner's name, address, and telephone number
2. Description of the dog or cat (species, breed, sex, markings, age, and name)
3. Date of vaccination
4. Date of vaccination expiration
5. Rabies vaccination tag number
6. Vaccine producer and product name
7. Manufacturer's serial or lot number of vaccine
8. Veterinarian's signature
9. Veterinarian's address and license number

The original certificate of rabies vaccination shall be provided to the owner. The veterinarian who administers the vaccination shall retain one copy. All parties should retain the certificate for the duration of the vaccination plus one year. A durable metal or plastic, serially numbered rabies tag issued by the veterinarian who administers the vaccine shall be provided to the owner with instructions that it must be securely attached to the dog's or cat's collar or harness.

- B. Duties of Owner The owner is responsible to procure rabies vaccination for his or her dog or cat as outlined above, and to secure a license. The owner is responsible to assure that his or her dog or cat wears a collar or harness with identification and the approved license or rabies tag securely attached. The license or rabies tag shall be worn at all times unless specific exemptions are set forth in the local ordinance.

Section IV - Transient or Show Dogs or Cats

Owners of dogs or cats who are temporarily visiting a specific rabies control jurisdiction with their dog(s) or cat(s) or who are exhibiting a dog or cat in competition, must carry with them and be prepared, upon demand of a legal authority, to present a current certificate of rabies vaccination for each dog or cat.

Section V - Management of Animals that Bite Humans

Anyone knowing of an animal bite to a human shall immediately report the bite to the

Rabies Control Authority or the Public Health Official.

A. Vaccinated Dogs, Cats, and Ferrets

1. A healthy dog, cat, or ferret that is currently vaccinated against rabies and that bites or reportedly bites a human will be examined by a licensed veterinarian, who will determine the animal's health status. If no signs of illness compatible with rabies are detected, the animal will be confined under such conditions as are outlined in an official quarantine order issued by the Rabies Control Authority or Public Health Official and observed for a period of 10 days from the date of the bite. Instead of being quarantined, the animal may be humanely euthanized and tested for rabies in an approved laboratory.

Animals under confinement and observation may be treated by a veterinarian, but rabies vaccine should not be administered to the animal until the confinement period is complete. At the end of the confinement period the dog, cat, or ferret will receive a well check by an animal control officer and may be required to be reexamined by a veterinarian. The results of the veterinary examinations will be documented and communicated to the Rabies Control Authority, the Public Health Official, and the owner.

2. If at the end of the confinement and observation period, the dog, cat, or ferret shows no signs of illness compatible with rabies, it may be released from confinement with the approval of the Rabies Control Authority or the Public Health Official.
3. If at any time during confinement or upon examination, the dog or cat shows signs of illness compatible with rabies, the animal shall be humanely euthanized and tested for rabies in an approved laboratory at the discretion of Rabies Control Authority or the Public Health Official after conferring with the examining veterinarian.

B. Dogs, Cats, and Ferrets that are Not Currently Vaccinated against Rabies

1. A dog, cat, or ferret that is not currently vaccinated against rabies that bites or reportedly bites a human will be considered a rabies suspect and will be seized by the Rabies Control Authority, confined and observed under such conditions as are outlined in an official quarantine order issued by the Rabies Control Authority or Public Health Official. The confinement and observation shall be conducted under the supervision of an animal control officer for a period of not less than 10 days from the date of the bite. Instead of being confined and observed, the animal may in some circumstances be humanely euthanized and tested for rabies in an approved laboratory. Confined animals may be treated by a veterinarian, but rabies vaccine should not be administered to the animal until the observation period is complete.
2. The rabies suspect dog, cat, or ferret will be examined by a licensed veterinarian or ACO at the beginning and at the end of the confinement and observation

period, to determine its health status. The results of the examination will be recorded and communicated to the Rabies Control Authority, the Public Health Official, and the owner.

3. If at any point during the confinement and observation period or upon examination, the dog, cat, or ferret shows signs of illness compatible with rabies, the Rabies Control Authority or the Public Health Official will order the immediate humane euthanasia and rabies testing of the animal in an approved laboratory after conferring with the examining veterinarian.
4. If at the end of the confinement and observation period the dog, cat, or ferret shows no signs of illness compatible with rabies, it may be released from confinement with the approval of the Rabies Control Authority or the Public Health Official. Prior to its release, the dog, cat, or ferret will be vaccinated against rabies at the owner's expense. Alternatively, the dog, cat, or ferret will be vaccinated within 72 hours of release. The owner will pay to the Rabies Control Authority a prescribed rabies vaccination deposit that will be reimbursed upon the presentation of proof of rabies vaccination by a private veterinarian.

C. Other Animals

1. Animals, other than dogs, cats, or ferrets, that bite or reportedly bite a human will, at the discretion of the Public Health Official, be treated according to the circumstances of exposure, the species, and the presence of rabies in the area. The pathogenesis and length of incubation and virus shedding periods of rabies in those other animals is unknown.
2. The animal may at the discretion of the Public Health Official, be seized by the Rabies Control Authority and immediately euthanized for rabies testing in an approved laboratory. Reports of the laboratory test will be provided to the Rabies Control Authority, the Public Health Official, the bite victim and the submitting veterinarian.

Section VI - Animals that are Bitten by or Potentially Exposed to Rabid or Suspect Rabid Animals

A. Dogs, Cats, or Ferrets Currently Vaccinated Against Rabies

1. A currently vaccinated dog, cat, or ferret that is bitten by, or otherwise potentially exposed to a rabid or suspect rabid animal will be revaccinated immediately and observed for 45 days.
2. If at any point during the observation period the dog, cat or ferret shows signs of illness compatible with rabies, the Rabies Control Authority or the Public Health Official will order the immediate humane euthanasia and rabies testing in an approved laboratory of the animal after conferring with the examining

veterinarian.

B. Dogs, Cats, or Ferrets that are Unvaccinated or Not Currently Vaccinated against Rabies.

1. A dog, cat, or ferret that is not currently vaccinated against rabies and is bitten by or otherwise potentially exposed to a rabid or suspect rabid animal shall be euthanized immediately.
2. If the owner is unwilling to consent to euthanasia, the animal must be isolated for a period of not less than six months. The animal must remain in strict isolation at home or at a state-licensed animal facility at the owner's expense under such conditions as are outlined in an official isolation order issued by the Rabies Control Authority. The animal will be vaccinated against rabies upon entry into isolation or one month prior to release.
3. At the end of the six-month isolation, the dog, cat, or ferret will be examined by a licensed veterinarian who will report the results of the examination to the Rabies Control Authority or Public Health Official.
4. If the examination determines that the dog or cat is free of signs of illness compatible with rabies, it may be released from isolation with the approval of the Public Health Official.
5. If at any point during the isolation period or upon examination, the dog, cat or ferret shows signs of illness compatible with rabies, the Rabies Control Authority or the Public Health Official will order the immediate humane euthanasia and testing of the isolated animal after conferring with the examining veterinarian.

C. Livestock

1. Currently vaccinated livestock bitten by or otherwise potentially exposed to rabid or suspect rabid animal will be revaccinated immediately and observed for 45 days.
2. Unvaccinated livestock should be slaughtered immediately. If the owner is unwilling to have this done, the animal will be kept in strict isolation for six months under such conditions as are outlined in an official isolation order issued by the Rabies Control Authority.

D. Other Animals

Any animal, other than a dog, cat, ferret, or livestock that is bitten by or otherwise potentially exposed to a rabid or suspect rabid animal should be euthanized immediately. Animals maintained in USDA-licensed research facilities or accredited zoological parks that are exposed or potentially exposed to rabies shall be evaluated on a case-by-case basis by the Rabies Control Authority or the Public Health Official.

E. Testing of Suspect Rabid Animals

If a suspect rabid animal is available for testing, an animal that was bitten by or otherwise potentially exposed to the suspect rabid animal will be isolated pending the rabies testing result on the suspect animal. If the testing results are negative, the bitten or otherwise potentially exposed animal shall be released with the approval of the Rabies Control Authority or Public Health Official.

Section VII - Impoundment of Animals found in violation of this code.

- A. The Rabies Control Authority shall operate a shelter or shelters, or the Rabies Control Authority may enter into a cooperative agreement with a licensed veterinarian or other organization for the establishment and operation of a quarantine facility.
- B. Any animal that is found off the owner's premises running at large or without a valid rabies vaccination tag shall be impounded. All impounded animals shall be given proper care and maintenance.
- C. Notice of impoundment of all animals, including any significant identification marks, shall be posted at the shelter as public notification of impoundment.
- D. An owner may reclaim a vaccinated animal that is impounded for lack of a rabies vaccination tag by furnishing proof of rabies vaccination and paying all impoundment and licensing fees prior to release.
- E. An owner may reclaim an unvaccinated animal during the period of impoundment by paying the prescribed shelter and rabies vaccination fees of \$. A rabies vaccination must be administered prior to or within 72 hours of release. If rabies vaccination is not performed prior to or at the time of release, arrangements will be made by the local government to reimburse the rabies vaccination fee to a veterinarian designated by the owner after receipt of proof of vaccination.

Section VII - Penalties for Violation of Ordinance

Any animal owner who fails to comply with any of the provisions of this ordinance shall be guilty of an infraction and subject to a fine of not less than \$ ___ nor more than \$ ___.

Section VIII - Shelter Fees

Impoundment fees shall be paid by the owner.

Section IX - Enforcement

It shall be the responsibility of the _____ to administer this ordinance, and to promulgate the necessary rules and regulations for its implementation. Enforcement shall be the responsibility of _____

Effective _____ in the (city, town, village, or county) of _____ all regulations pertaining to rabies control (and licensing) will be enforced by the (local, county, or state) enforcement officers, or others with regulatory authority specified by the governing unit.

Explanatory Notes

Communities that require licensure of dogs or cats may insert the following sections in the model ordinance:

Licensing

Effective (date) _____ in the (city, town, village, or county) of _____ every dog or cat 4 months of age and older shall be licensed. On proof of rabies vaccination in accordance with Section II of this ordinance, and upon application for licensure and payment of the required fee to the clerk (city, town, village, or county) of _____, a license shall be issued.

All licenses will expire _____, and each year thereafter.

Fees

The license fees shall be as follows:

- Male (sexually intact)
- Male (neutered)
- Female (sexually intact)
- Female (neutered)

NOTE: Rabies vaccinations may be recommended for animals other than dogs, cats, and ferrets for which a USDA licensed vaccine is available; however a current vaccination history may not eliminate the need for euthanasia and rabies testing if the animal bites a human.

MUNICIPALITIES' RESPONSIBILITY TO RABIES CONTROL

RABIES CONTROL AND PREVENTION PROGRAMS

The goals of rabies control and prevention programs are to 1) prevent human cases of rabies, 2) prevent human exposure to actual or potential rabies situations, thereby averting the need for and expense of human post-exposure treatment, and 3) to prevent rabies in domesticated animals.

Response Plan

A local response plan, spearheaded by municipal officials, should be developed using input from appropriate members of the community: the public health officer, animal control officer, director of the animal shelter, representatives from each veterinary practice and hospital emergency departments in the area, a representative from the school system, a member of the police department, the local game warden, and others that the planning team may consider relevant. This committee should identify personnel and resources which can provide:

1. Education for school children and the general public to inform them of the risks and what steps they can take to protect themselves against rabies.
2. A strong animal control program enforcing dog licensing to limit stray animals and insuring compliance with vaccination laws for both dogs and cats.
3. A coordinated response team for dealing with rabies exposures, which will address how to deal with the animal involved (including wild animals) and its testing, as well as post-exposure treatment.

When situations of actual or potential rabies exposures occur, it is extremely helpful to have in place a network of people and facilities that can deal with each of the following details:

1. Capture of suspect rabid animals.
2. Euthanasia of suspect animals.
3. Deciding which animals are to be tested for rabies.
4. Decapitation of suspect animals.
5. Preparing and transporting carcasses to the HETL for testing.
6. Disposal of carcasses after decapitation.
7. Facilities which can quarantine dogs and cats which have exposed humans.
8. Personnel to oversee quarantine of owned animals.
9. Professionals who can act as sources of information to the public about rabies issues.
10. Establish a stray animal placement policy.

Liability

The municipality is responsible for expenses incurred in a rabies incident involving a stray domesticated animal. If the suspect animal is owned, the owner is responsible (22 MRSA §1313-B). Transportation costs for wildlife is the responsibility of IF&W. The town, usually through the ACO, is responsible for arranging transportation of the animal to the HETL in Augusta.

Establishment of a Stray Animal Placement Policy

Adoption of dogs and cats is an extremely popular way for people to acquire pets. It is important that a policy be established by municipalities and animal shelters for handling their strays. The primary goal should be to protect the human population and to humanely care for the pet population. It would be unfortunate if all adoptions were eliminated due to a rabies panic and tragic, if an exposed animal were adopted out and then developed rabies. It is recommended that impounded, unclaimed stray animals should not be offered for adoption if they have the appearance of having been out in the wild for a considerable period of time, or if they have evidence of wounds of unknown origin. Vaccination status and any wound history should be obtained if possible and evaluated before offering the animal for adoption. If rabies is endemic to the area, adoptive owners should be warned of the threat, especially if their new pet has an unknown vaccination history. Information on rabies should be available to everyone visiting the facility (see “Your New Pet and Rabies”).

Equipment for the ACO

The right equipment, in serviceable condition, is essential for an animal control officer to perform his/her duties. Listed below is equipment that is recommended to properly equip the animal control officer:

1. Animal handling gloves - thick bite-proof gloves, elbow length
2. Control pole
3. Muzzle
4. Leash
5. Training choke collar - adjustable chain collar
6. Non-injuring live trap
7. Stretcher or blanket
8. Large cage for transporting live animals
9. Official identification card
10. Printed warnings and calling notices
11. Dog/cat food, water, and containers to hold them
12. Flea spray
13. One gallon of bleach - equipment, cages and contaminated areas and surfaces should be washed with detergent and water, and disinfected with a freshly prepared solution of bleach (1/2 cup per gallon of water).
14. Long handle brush (toilet bowl brush)
15. Rubber gloves, elbow length
16. Plastic sheeting or body bag
17. Waterproof container
18. Safety goggles or full face mask, and protective covering for clothing

Additional equipment is needed for controlling, capturing and transporting suspected rabid animals. Contaminated areas where the suspected rabid animal's saliva, brain and spinal cord tissues (and possibly blood if the saliva, brain or spinal cord tissues have been mixed together due to shooting or other means) must be secured from humans and animals. For additional information see the “Rabies Testing/Specimen Preparation (Decapitation)” section.

FORMULATION OF RABIES PREVENTION POLICIES IN ANIMAL FACILITIES

All facilities and people who handle animals including veterinary hospitals, animal shelters and humane societies, animal control officers, game wardens, wildlife rehabilitators and biologists, animal damage control cooperators, boarding kennels, and rescue and volunteer organizations should become familiar with rabies issues, and develop local or in-house protocols on how to handle rabies related situations using the Rabies Management Guidelines. Animal control officers, veterinary hospitals, animal shelters and humane societies are usually the first to become involved in a potential rabies situation. Establishing policies to deal with that first rabies suspect will allow the situation to be handled safely and professionally.

Public education is the key to reducing the risk of rabies among domesticated animals and humans. Animal care facilities and animal control officers have the opportunity and the responsibility to see that accurate information is presented to the public. Staff should have the knowledge to respond quickly and appropriately in a rabies situation, either by giving the public direct information, or by referring them to the appropriate professionals for assistance.

The following points should help those who work with animals to formulate a rabies plan for their facility:

Plan ahead

It is very useful to make arrangements, before there is an emergency, with animal control officers, animal shelters and humane societies, veterinarians, town officials, police departments, sheriff's departments, game wardens, wildlife rehabilitators, animal damage control cooperators and courier services, all of whom may become involved in reporting, catching, destroying, decapitating, transporting and/or sheltering animals. Local police departments are a vital group since they are often called on in emergency situations involving suspect rabid animals. It is critical that police officers and others not normally involved in handling animals be instructed in the appropriate way to handle suspect animals, including when and where it is and is not suitable to shoot an animal. Familiarity with local game wardens and emergency response procedures is helpful. It is important to decide how your facility will handle situations involving animals other than dogs, cats, and ferrets. Wild animals are dealt with very differently in regards to rabies exposures than are dogs, cats and ferrets.

Educate the staff

Everyone, including animal control officers, game wardens, all facility staff members, volunteers, and board members should become familiar with animal handling protocols and/or this Rabies Management Manual and the procedures it outlines. The staff should be able to deal calmly and effectively with the public to dispel fears and give accurate information.

Post a contact list

A contact list, like the one at the beginning of this manual, should be posted near each telephone with routine and emergency numbers of the local and state officials and agencies that are involved in handling rabies situations.

Establish a human pre-exposure vaccination policy

All animal control officers, game wardens, animal shelter and humane society employees, veterinary hospital staff, wildlife rehabilitators and biologists, and any other high-risk personnel should seriously consider receiving pre-exposure vaccination. Each staff member should be informed of the availability of immunization, and should then talk to their health care provider to discuss the details of the procedure. Management of the animal facility may want to consider having staff members sign a statement attesting to the fact that pre-exposure vaccination has been discussed, with signed agreement or refusal. Periodic serologic testing and/or booster immunizations according to the employee's risk category must also be considered.

Establish a human post-exposure policy

If a staff member is bitten by a suspect rabid animal, the wounds must be flushed immediately and washed thoroughly with soap and water, and a health care provider must be contacted at once. The necessity for post-exposure rabies treatment or animal quarantine will be decided on a case by case basis by the attending physician and Maine CDC. Note that staff members at an animal facility cannot legally give any advice to another staff person or the public on treating human bite wounds or exposures to rabies; this must be left to a physician. It is important to keep accurate records of all human and domesticated animal exposures which occur in your facility, or which are reported to your staff. Many animal facilities are using some type of rabies exposure log where incidents can be recorded for later follow-up.

Establish a pet pre-exposure vaccination policy

All rabies vaccinations for cats, dogs and ferrets must be administered by a veterinarian. This is state law and the only way to assure the public that the pet has been properly vaccinated. Within 28 days after an initial vaccination, a peak rabies antibody titer is reached and the pet can be considered to be currently immunized. Pets that are maintained on a proper re-immunization schedule may be considered to be currently immunized directly after a booster dose. It is important to question the vaccination status of all animals, in order to advise on an immunization schedule, or to add rabies to the differential diagnosis if the animal is showing signs of illness. Note that immunosuppressed or ill animals may not be able to mount an adequate immune response to vaccination. Veterinarians may want to vaccinate some animals more frequently and avoid giving corticosteroids concurrently with rabies vaccine.

Establish a policy on pets exposed to rabies

Veterinary hospitals should establish protocols for handling pets exposed to known or suspected rabid domesticated animals or wildlife. Again, keeping records of these exposures in a separate log is a good idea.

Animal facilities and animal control officers face the problem of how to safely treat a pet with an abscess or bite wound of unknown origin, once rabies is in the area. The following points will help in these situations:

1. Be extremely cautious and wear gloves when handling animals with suspicious wounds. The wounds of these animals may contain viable rabies virus from the saliva of the infected animal. Gloves should be worn when handling these animals, especially if it is within two hours of the incident. Owners handling such animals (especially if they have done so directly after the wounds were sustained) should wash with soap and water at once and be referred to their health care provider.

2. Determine if an injured pet has bitten anyone. If so, the local animal control officer must be notified. In most cases these pets will be confined and observed for a period of 10 days.
3. The animal's owner must be advised of their pet's potential exposure to rabies, and referred to their health care provider.
4. Isolation for a period of six months is necessary for dogs, cats and ferrets which have been exposed to rabies and which are not currently vaccinated for rabies. Individual animal facilities must decide whether they are willing to provide this kind of care for owners who can't confine pets at home. Protocol would be similar to that for confinement of biting animals.

Establish a policy for pets showing signs of rabies

Proper handling of suspect animals is essential to ensure the safety of the public and the person handling the animal. Dogs, cats and ferrets which bite humans must be confined and observed for ten days. Each facility will need to establish policies for handling confined animals. Animals, which show signs of rabies (behavioral changes or neurological signs), should be evaluated by a veterinarian for possible rabies testing.

Establish a stray animal placement policy

See the section on "Municipalities' Responsibilities to Animal Control" and the "Animal Shelter Adoption Disclaimer." Animal shelters and municipalities should work together to formulate a policy.

Confinement guidelines for animal facilities

1. Confine nothing unless you can be sure of safely and humanely confining the suspect animal. Escape must not be a possibility.
2. Ideally, confined animals should be kept in cages that are divided by guillotine-type doors, so one side may be cleaned while the animal is moved without handling to the other side. If this isn't possible, handling must be minimal and should be by one or two staff people (preferably who have had pre-exposure vaccination) using appropriate equipment (gloves, restraint poles, squeeze bars, etc.). Records should be kept of all staff persons who have contact with the animal.
3. Confined animals should not be accessible to the public. Cages should be clearly marked with rabies warnings in red, orange or neon. Cages should be kept locked.
4. Solid walls should separate quarantined animals from other animals. Animals must not be able to touch other animals, and saliva must not be able to reach other cages or runs.
5. Cages, dishes, and litter pans must be in good condition so they can be easily disinfected every day. Disinfection can be with alcohol (40-70% ethanol), freshly prepared bleach solution (1/2 cup per gallon water), iodine (25 ppm) or quaternary ammonium (200 ppm) compounds.
6. Confined animals should be observed carefully several times daily for signs of illness or behavior changes. If any changes occur, the animal should be immediately examined by a veterinarian to determine if euthanasia and rabies testing are necessary.



**Maine Department of Health and Human Services
Maine Center for Disease Control and Prevention
Division of Infectious Disease**

Human Rabies Post-Exposure Prophylaxis (PEP) Reporting Form

Reporting Information

Date of report: _____ / _____ / _____
 Name of person reporting: _____ Title: _____
 Agency/institution: _____ Phone: _____

Patient Information

Name (First, MI, Last): _____
 Street address: _____
 Town: _____ State: _____ Zip: _____
 County: _____ Phone: _____
 Date of birth: _____ / _____ / _____ Age: _____ Gender: Male Female

Provider Information

Name: _____ Phone: _____
 Practice: _____ Practice town: _____

PEP Administered

Vaccine Vaccine + Immune globulin

Vaccine Information

Facility where first dose administered: _____ Date of administration: _____ / _____ / _____

Immune Globulin Information

Facility where administered: _____ Date of administration: _____ / _____ / _____

Exposure Information

Date of exposure: _____ / _____ / _____ Town of exposure: _____
 Type of exposure: Bite Scratch Mucous membrane Unknown
 Other: _____
 Exposure site: Leg Face Trunk Arm Hand/Finger
 Other: _____
 Index animal type: Cat Dog Ferret Horse Cow Sheep
 Raccoon Skunk Fox Bat Woodchuck Unknown
 Other: _____
 Animal Status: Owned Stray Wild Unknown
 If owned, owner's name: _____ Owner telephone: _____

Describe exposure scenario:

Has an Animal Control Officer or other responder been contacted? Yes No Unknown

Name of Officer: _____ Officer telephone: _____

Clinical Information

Is the patient immunosuppressed? Yes No Unknown
 Has the patient ever received rabies vaccine? Yes No Unknown
 If yes, reason: Animal professional Travel Previous rabies exposure
 Other: _____

Fax form to Division of Infectious Disease at (800) 293-7534

Index

Animal

- Domesticated 1, 4-6, 16-17, 23, 25, 28, 30-31, 35-36
 - Owned 5, 24-25, 32
 - Cat 4, 6, 8, 10, 15-17, 23-25, 27, 30-31, 42
 - Dog 4, 6, 8, 10, 15-17, 23-25, 27, 30-31, 33, 38, 41-42
 - Exotic pet (i.e., Vietnamese potbellied pig) 23-25, 32, 41
 - Ferret 4, 10-11, 15-17, 24-26, 30-31, 41
 - Livestock 4-5, 8, 16, 18, 23-26, 30-34, 41
 - Cattle (See Cow)
 - Cow 5, 8-10, 16-17, 24, 26, 32-33
 - Goat 5, 24-25
 - Horse 5, 8, 10, 16, 17, 24-25, 32-33
 - Monkey 16, 25
 - Llama 16
 - Pig (or swine) 5, 16, 24-25, 33
 - Sheep 5, 8, 17, 24, 26, 32-33
 - Stray 6, 24, 25, 36, 41-42
 - Cat 6, 8-9, 25
 - Dog 24-25
 - Ferret 24-25
- Undomesticated 1, 6, 8, 10, 16, 23-24, 28, 30, 32, 36, 41
 - Bat 3, 8-9, 14-17, 24, 27-28, 30-32, 35
 - Bobcat 8, 16, 28
 - Coyote 9, 16, 24, 28
 - Deer 24
 - Fox 8-9, 16, 24, 28, 33
 - Groundhog (See woodchuck)
 - Lagomorph 16, 26
 - Hare 16, 26
 - Rabbit 9, 16, 24, 26
 - Opossum 9, 16, 26
 - Otter 16
 - Porcupine 16
 - Raccoon 8, 16, 24, 28, 41
 - Rodent 9, 16, 24, 26
 - Chipmunk 16, 24, 26
 - Gerbil 16, 24, 26
 - Gopher 16, 26
 - Hamster 16, 24, 26
 - Mole 24, 26
 - Mouse 16, 24, 26
 - Muskrat 17
 - Prairie Dog 16
 - Rat 16, 24, 26
 - Squirrel 16, 24, 26
 - Vole 24
 - Woodchuck 8-9, 16, 24
 - Skunk 8-9, 14-16, 24, 28, 31, 33, 36
 - Weasel 4, 16
 - Wildlife hybrid 6, 8, 24, 28
 - Wolf 9

Animal bites 2, 23, 25-26
 Animal Control Officer (ACO) 3-4, 15, 24-28, 30, 32, 34, 36, 38-39, 41-42
 Animal Damage Control Cooperator (ADC) 4, 28-29
 Animal rabies vaccine 6, 15, 28, 31-32, 41
 Booster dose 4, 25, 27, 30, 41-42
 Certificate of vaccination 4, 33, 42
 Exemption form (See Waiver form)
 Waiver form 33, 42
 Animal shelter 25, 36, 42
 Attack 5, 9, 16-17, 23, 33
 Provoked 5, 14, 17
 Unprovoked 6, 14, 17, 24
 Bites (see Animal bites)
 Carcass disposal 37
 Confinement and observation (10-day) 4, 11, 14-17, 23-26, 31
 Conditions of confinement 24-25, 31
 Control measures 1, 8, 30, 42
 Booster and 45-day observation 5, 27, 30-32
 Euthanasia 25, 32
 Booster and 6-month isolation 5, 27, 30-32
 Booster and 6-month observation 30
 Decapitation 4, 23-26, 34-37
 Immune Globulin (See Human Rabies Immune Globulin)
 Isolation 5, 26-27, 30-32, 34
 Human Rabies Immune Globulin (HRIG) 12, 19-22, 38
 Adverse reactions 12, 22
 HyperRab 12
 Imogam 12, 22
 Patient assistance programs 22
 Sanofi Pasteur (See Imogam)
 Talecris Biotherapeutics (See HyperRab)
 Human rabies vaccines 5, 12, 19, 20-22, 37-40
 Adverse reactions 12, 22
 Antibody titer (See Serologic testing)
 Booster doses 39-40
 Human Diploid Cell Vaccine (HDCV) 12, 19-21, 39-40
 Imovax (See Human Diploid Cell Vaccine)
 Novartis (See Purified Chick Embryo Cell Vaccine)
 Purified Chick Embryo Cell Vaccine (PCECV) 12, 19-21, 39-40
 RabAvert (See Purified Chick Embryo Cell Vaccine)
 Sanofi Pasteur (See Human Diploid Cell Vaccine)
 Serologic testing 22, 39-40
 Milwaukee Protocol 10
 Non-exposure 5
 PEP (see post-exposure prophylaxis)
 Porcupine quills (See Porcupine in Animal, Undomesticated)
 Post-exposure prophylaxis 2, 5, 8, 12-17, 19-22, 26-28, 37-38, 40
 Assessment 12-19, 26
 Children 20-21, 23, 41
 Deviations from schedule 20
 Immune-compromised persons 20
 Interchangeability of vaccines 20
 Patient assistance programs 22
 Pregnancy 22

Previously unvaccinated persons	19, 21
Previously vaccinated persons	20-21
Pre-exposure prophylaxis	5, 8, 22, 37-40
Immune-compromised persons	22
Patient assistance programs	22
Prevention	12, 38-42
Pre-exposure vaccination (See Pre-exposure prophylaxis)	
Education	41
Pet vaccination	41
Local animal control	42
Wildlife control and management	42
Proximity (See Exposure under Rabies, virus)	
Quills (See Porcupine in Animal, Undomesticated)	
Rabies, disease	5
Animal	2, 8
Biologics	12, 22, 38-39
Diagnosis	11, 22
Epidemiology	8, 14, 16, 18, 25
Human	2, 8, 10, 14, 16-17
Incubation period	5, 9-10, 28
Infectious period	11
Pathogenesis	9
Reporting	2
Response	23-29
Euthanize & submit for testing	24-26, 28
10-day confinement and observation (See Confinement and observation, 10 days)	
Signs and symptoms	2, 8-11, 23-24, 26, 28, 32-34
Stages of infection	10-11
Susceptibility	6, 9, 32
Testing	5, 11, 23-24, 35
Transmission	4, 9, 14-17, 26-28, 32
Vaccines (See Animal rabies vaccines OR Human rabies vaccines)	
Variant	8, 14, 17
Rabies, virus	8-12, 14-18, 24, 28, 30, 32, 37-38
Biology	8
Exposure	4-5, 6, 8-9, 11-18, 23, 30, 32, 37, 39, 41
Bite (See Animal bite)	
Proximity	27, 30
Wound of unknown origin	30
Survival in the environment	10, 15
Special circumstances	24-26, 28
Service dogs	25
Unusual circumstances (See Special circumstances)	
Vaccination status, animal	4, 14, 17, 21, 23-25, 30, 33
Currently vaccinated	4-5, 17, 30, 32, 34, 42
Unvaccinated	6, 30, 31, 32, 34
Wild animal (See Animal, undomesticated)	
Wildlife rehabilitators	28-29, 38, 41-42
Wound of unknown origin (See Exposure under Rabies, virus)	
Zoonotic Disease	6, 8

**Maine Rabies Workgroup
Membership as of May 30, 2012**

Chairs: Don Hoenig, VMD, Maine Department of Agriculture
Susan Manning, MD, MPH, Maine CDC

Members (by agency):

Maine CDC

Lauren Ball, DO, MPH
Stephen Combes, MS, MPH
Julie Crosby
Philip A. Geyer
Stephen Sears, MD, MPH
Anne Sites, MPH, CHES
Patricia Bosse, MPH

Maine Animal Control Association

Heidi Nelson

Maine Department of Agriculture

Christine Fraser, DVM
Liam Hughes
Elizabeth O. McEvoy, DVM
Elizabeth Somers

Maine Department of Inland Fisheries & Wildlife

John DePue
Lt. Adam Gormely
Major Gregory Sanborn

Maine Federation of Humane Societies

Steve Dostie

Maine Veterinary Medical Association

Julie Krasne, DVM
Kristen Mugnai, DVM

USDA APHIS Wildlife Services

John Forbes
Jesse W. Morris
Kirk Shively

University of Maine Cooperative Extension

David Marcinkowski, Ph.D.